



RUSHMOOR BOROUGH COUNCIL

DEVELOPMENT MANAGEMENT COMMITTEE

***Wednesday, 30th March, 2016,
at 7.00 p.m.***

To:

VOTING MEMBERS

Cr. G.B. Lyon (Chairman)
Cr. B.A. Thomas (Vice-Chairman)

Cr. D.B. Bedford
Cr. D.M.T. Bell
Cr. R. Cooper

Cr. P.I.C. Crerar
Cr. Sue Dibble
Cr. Jennifer Evans

Cr. D. Gladstone
Cr. C.P. Grattan
Cr. J.H. Marsh

NON-VOTING MEMBER

Cr. R.L.G. Dibbs - Cabinet Member for Environment and Service Delivery
(ex officio)

STANDING DEPUTIES

Cr. S.J. Masterson
Cr. P.F. Rust



Mr. Chairman, Ladies and Gentlemen,

You are hereby summoned to a Meeting of the **Development Management Committee** which will be held in the Concorde Room at the Council Offices, Farnborough on Wednesday, 30th March, 2016 at 7.00 p.m. for the transaction of the business set out below.

Yours faithfully,

A.E. COLVER
Head of Democratic Services

Council Offices
Farnborough

17th March, 2016

Enquiries regarding this Agenda should be referred to Lauren Harvey,
Administrative Assistant, Democratic Services (Tel: (01252) 398827 or e-mail:
lauren.harvey@rushmoor.gov.uk)

A full copy of this agenda can be found at the following website:
<http://www.rushmoor.gov.uk/8920>

A g e n d a

1. **Declarations of interest –**

All Members who believe they have a disclosable pecuniary interest in any matter to be considered at the meeting may not participate in any discussion or vote taken on the matter and if the interest is not registered, it must be disclosed to the meeting. In addition, Members are required to leave the meeting while the matter is discussed.

2. **Minutes –**

To confirm the Minutes of the Meeting held on 2nd March, 2016 (copy attached).

Items for decision

3. **Planning applications –**

To consider the Head of Planning's Report No. PLN1610 on planning applications recently submitted to the Council (copy attached with a copy of the index appended to the agenda).

4. **Appeals progress report –**

To consider the Head of Planning's Report No. PLN1611 (copy attached) on the progress of recent planning appeals.

**Index to Development Management Committee Agenda
30th March 2016
Report No. PLN1610**

Item No.	Reference Number	Address	Recommendation	Page No.
1	15/00897/REMPP	Zone C - Cambridge Military Hospital Aldershot Urban Extension Alisons Road Aldershot	For Information	14
2	15/00898/REMPP	Zone C - Cambridge Military Hospital Aldershot Urban Extension Alisons Road Aldershot	For Information	14
3	15/00930/LBC2PP	Zone C - Cambridge Military Hospital Aldershot Urban Extension Alisons Road Aldershot	For Information	15
4	15/00931/LBC2PP	Zone C - Cambridge Military Hospital Aldershot Urban Extension Alisons Road Aldershot	For Information	15
5	16/00007/FULPP	Land At Dingley Way Farnborough	For Information	15
6	16/00027/FUL	ASDA Westmead Farnborough	For Information	15
7	16/00133/REMPP	Zone E - Gunhill Aldershot Urban Extension Alisons Road Aldershot	For Information	16
8	16/00049/FULPP	The Queens Head 97 North Lane Aldershot	Grant	17
9	16/00097/FUL	St Josephs Roman Catholic Primary School Bridge Road Aldershot	Grant	44
10	15/00925/FULPP	Land Off Sarah Way, To The Rear Of 49-51 Victoria Road Farnborough	Grant	54

Development Management Committee
30th March 2016

Head of Planning

Declarations of interest

Name: Cllr _____

N.B. A declaration is not required for items that appear either in Section D of the Planning Report or the Appeals Progress Report as such items are for noting only.

Agenda Item No.	Planning Application No.	Application Address	Reason

DEVELOPMENT MANAGEMENT COMMITTEE

Meeting held on Wednesday, 2nd March, 2016 at the Council Offices,
Farnborough at 7.00 p.m.

Voting Members

Cr. G.B. Lyon (Chairman)
Cr. B.A. Thomas (Vice-Chairman)

Cr. Mrs. D.B. Bedford	a	Cr. P.I.C. Crerar	a	Cr. D.S. Gladstone
Cr. D.M.T. Bell		Cr. Sue Dibble		Cr. C.P. Grattan
Cr. R. Cooper		Cr. Jennifer Evans		Cr. J.H. Marsh

Non-Voting Member

Cr. R.L.G. Dibbs (Cabinet Member for Environment and Service
Delivery) (ex officio)

Apologies for absence were submitted on behalf of Crs. P.I.C. Crerar
and Cr. D.S. Gladstone.

Cr. S.J. Masterson attended as standing deputy in place of Cr. P.I.C.
Crerar.

75. DECLARATION OF INTEREST –

Having regard to the Members' Code of Conduct, the following
declaration of interest was made. The Member with a disclosable pecuniary
interest left the meeting during the debate on the relevant agenda item:

Member	Application No. and Address	Interest	Reason
Cr. B.A. Thomas	15/00964/FUL (St Joseph's Roman Catholic Primary School, Bridge Road, Aldershot)	Prejudicial	Proximity of home to the site.
Cr. B.A. Thomas	16/00049/FULPP (The Queen's Head, 97 North Lane, Aldershot)	Prejudicial	Ran a public house close to the application premises.

76. **MINUTES –**

The Minutes of the Meeting held on 3rd February, 2016 were approved and signed by the Chairman.

77. **TOWN AND COUNTRY PLANNING ACT, 1990 (AS AMENDED) -
TOWN AND COUNTRY PLANNING (GENERAL DEVELOPMENT
PROCEDURE) ORDER, 1995 -
DEVELOPMENT APPLICATIONS GENERALLY –**

RESOLVED: That

- (i) planning permission/consent be refused in respect of the following application as set out in Appendix “A” attached hereto for the reasons mentioned therein:

* 15/00964/FUL (St Joseph’s Roman Catholic Primary School, Bridge Road, Aldershot).

- (ii) the applications dealt with by the Head of Planning, where necessary in consultation with the Chairman, in accordance with the Council’s Scheme of Delegation, more particularly specified in Section “D” of the Head of Planning’s Report No. PLN1607, be noted;

- (iii) the current position with regard to the following applications be noted pending consideration at a future meeting:

15/00897/REMPP (Zone C – Cambridge Military Hospital, Aldershot Urban Extension, Alisons Road, Aldershot);

15/00898/REMPP (Zone C – Cambridge Military Hospital, Aldershot Urban Extension, Alisons Road, Aldershot);

15/00930/LBC2PP (Zone C – Cambridge Military Hospital, Aldershot Urban Extension, Alisons Road, Aldershot);

15/00925/FULPP (Land off Sarah Way, to the rear of Nos 49 – 51 Victoria Road, Farnborough);

15/00931/LBC2PP (Zone C – Cambridge Military Hospital, Aldershot Urban Extension, Alisons Road, Aldershot);

16/00007/FULPP (Land at Dingley Way, Farnborough);
and

16/00027/FUL (Asda, Westmead, Farnborough).

- (iv) Planning Application No. 16/00049/FULPP (The Queen’s Head, 97 North Lane, Aldershot), as amended at the meeting, be deferred.

* The Head of Planning's Report No. PLN1607 in respect of these applications was amended at the meeting.

78. REPRESENTATIONS BY THE PUBLIC –

In accordance with the guidelines for public participation at meetings, the following representation was made to the Committee and was duly considered before a decision was reached:

Application No.	Address	Representation	In support of or against the application
15/00964/FUL	(St Joseph's Roman Catholic Primary School, Bridge Road, Aldershot)	Dr. C. McCafferty	In support

79. APPLICATION NO. 16/00049/FULPP – THE QUEEN'S HEAD, 97 NORTH LANE, ALDERSHOT –

The Committee received the Head of Planning's Report No. PLN1607 (as amended at the meeting) regarding the demolition of existing public house and re-development of site with two pairs of 2-bedroom semi-detached houses on road frontage with new access between leading to a pair of 3-bedroom semi-detached houses at rear of site (6 new dwellings in total), together with detached garages, parking spaces, turning area and associated landscaping (re-submission of planning application 15/00475/FULPP refused 18 September 2015).

It was noted that the recommendation was to defer consideration of the planning application and to issue an Enforcement Notice.

RESOLVED: That

- (i) consideration of the planning application be deferred to seek an independent assessment of the evidence submitted with the application; and
- (ii) the Council to issue an Enforcement Notice requiring the cessation of the unauthorised material change for the following draft reasons:
 - (a) the unauthorised development conflicts with the requirements of the Council's "Development Affecting Public Houses" Supplementary Planning Document formally adopted by the Council's Cabinet on 2 June 2015 in that it has not been satisfactorily demonstrated that there is no longer term need for the Public House and that alternative Public Houses are readily accessible to meet

the needs of the community in the vicinity. The unauthorised development thereby also results in the unjustified loss of a community facility contrary to Government Planning Policy and Guidance and also Policy CP10 of the Rushmoor Core Strategy (November 2011);

- (b) the unauthorised development does not address its impact upon the nature conservation interest and objectives of the Thames Basin Heaths Special Protection Area. The proposal is thereby contrary to the requirements of the Habitats Regulations Policies CP13 and CP15 of the Rushmoor Core Strategy adopted October 2011.

80. ENFORCEMENT AND POSSIBLE UNATUHORISED DEVELOPMENTS – 166 LOWER FARNHAM ROAD, ALDERSHOT –

The Committee received the Head of Planning's Report No. PLN1608 regarding the erection of roof outbuildings at 166 Lower Farnham Road, Aldershot. It was reported that the property was a two-storey detached house, located on the north west side of Lower Farnham Road. In June, 2016, a complaint had been received that a roof had been formed over the existing outbuildings to the rear of the site.

A site inspection had confirmed that a sloping roof had been formed over the existing flat roof outbuilding and court yard to the rear of the site by erecting an insulated, metal double skinned roofing panel roof, forming a continuation of the rear roof slope of the existing two storey height outbuilding over the single storey outbuilding. It was reported that the highest part of the new roof measured 2.59m and required planning permission as it exceeded 2.5m in height and was located within 2m of a boundary property. The owner had been advised to either remove the roof, reduce the height of the roof by 0.09m in order to comply with householder permitted development rights for outbuildings, or attempt to regularise the development through the submission of a retrospective planning application. The owner of the property had failed to respond and no planning application had been received.

The Committee was informed that the main issues were the impact on the character and appearance of the area and the impact upon the amenities of the occupiers of adjacent properties. It was highlighted that the roof was positioned to the rear of the site and was therefore screened from public view by the two-storey height outbuilding. The General Permitted Development Order (GPDO) 2015 did not specify any building materials for outbuildings and the development only required planning permission as the height of the new roof exceeded the allowance made by the GDPO by 0.09m.

It was considered that the unauthorised roofing does not cause any significant material harm to the visual character of the area or the amenities of neighbours. As such, it was considered that planning permission would be

granted by the Council, were a planning application submitted. In accordance with Policy PE3, it was considered that neither expedient nor reasonable for the Council to take enforcement action in respect of the breach of planning control that had taken place.

RESOLVED: That no further action be taken.

81. **APPEALS PROGRESS REPORT –**

The Committee received the Head of Planning's Report No. PLN1609 concerning the following appeals:

(1) **Appeal Decisions –**

Application No.	Description	Decision
15/00318/FULPP	Against the Council's decision to refuse planning permission for the erection of 2 three-bedroom semi-detached dwellings with associated access and parking on the land to rear of 42-44 Newfield Avenue, Farnborough.	Dismissed

RESOLVED: That the Head of Planning's Report No. PLN1609 be noted.

The Meeting closed at 8.08 p.m.

G.B. LYON
CHAIRMAN

**Development Management Committee
2nd March 2016**

Appendix "A"

Application No. & Date Valid: **15/00964/FUL** **20th January 2016**

Proposal: **Erection of 3 single storey extensions to provide 3 classrooms, a single storey hall extension and a detached single storey teaching block to provide 3 early years classrooms at **St Josephs Roman Catholic Primary School Bridge Road Aldershot Hampshire****

Applicant: **Mr Bill James**

Reasons: 1 The application has failed to demonstrate that car parking capacity, either on local streets within a reasonable distance of the school, or in off-street parking areas under the control of the school; can be made available and secured in the long term sufficient to accommodate the additional demand and vehicular activity which would result from the proposed expansion in pupil and teacher numbers. The development would therefore give rise to detrimental traffic and parking conditions on the surrounding highway contrary to the requirements of Core Strategy Policy CP16.

Planning Applications

1. Introduction

- 1.1 This report considers recent planning applications submitted to the Council, as the Local Planning Authority, for determination.

2. Sections In The Report

- 2.1 The report is divided into a number of sections:

Section A – FUTURE Items for Committee – Pages 14 to 16

Applications that have either been submitted some time ago but are still not ready for consideration or are recently received applications that have been received too early to be considered by Committee. The background papers for all the applications are the application details contained in the Part 1 Planning Register.

Section B – For the NOTING of any Petitions – Page 16

Section C – Items for DETERMINATION – Pages 17 to 71

These applications are on the Agenda for a decision to be made. Each item contains a full description of the proposed development, details of the consultations undertaken and a summary of the responses received, an assessment of the proposal against current policy, a commentary and concludes with a recommendation. A short presentation with slides will be made to Committee.

Section D – Applications ALREADY DETERMINED under the Council's adopted scheme of Delegation – Pages 72 to 86

This lists planning applications that have already been determined by the Head of Planning, and where necessary with the Chairman, under the Scheme of Delegation that was approved by the Development Management Committee on 17 November 2004. These applications are not for decision and are FOR INFORMATION only.

- 2.2 All information, advice and recommendations contained in this report are understood to be correct at the time of publication. Any change in circumstances will be verbally updated at the Committee meeting. Where a recommendation is either altered or substantially amended between preparing the report and the Committee meeting, a separate sheet will be circulated at the meeting to assist Members in following the modifications proposed. This sheet will be available to members of the public.

3. Planning Policy

- 3.1 Section 38(6) of the Town and Country Planning Act 1990 (As amended) requires regard to be had to the provisions of the development plan in the determination of planning applications. This comprises the Rushmoor Plan Core Strategy (October 2011), the Hampshire Minerals and Waste Plan adopted October 2013, saved policies of the Rushmoor Local Plan Review (1996-2011) and saved policy NRM6 of the South East Plan.
- 3.2 Although not necessarily specifically referred to in the Committee report, the relevant development plan will have been used as a background document and the relevant policies taken into account in the preparation of the report on each item. Where a development does not accord with the development plan and it is proposed to recommend that planning permission be granted, the application will be advertised as a departure and this will be highlighted in the Committee report.

4. Human Rights

- 4.1 The Human Rights Act 1998 (the Act) has incorporated part of the European Convention on Human Rights into English law. All planning applications are assessed to make sure that the subsequent determination of the development proposal is compatible with the Act. If there is a potential conflict, this will be highlighted in the report on the relevant item.

5. Public Speaking

- 5.1 The Committee has agreed a scheme for the public to speak on cases due to be determined at the meeting (Planning Services report PLN0327 refers). Members of the public wishing to speak must have contacted the Meeting Co-ordinator in Democratic Services by 5pm on the Tuesday immediately preceding the Committee meeting. It is **not** possible to arrange to speak to the Committee at the Committee meeting itself.

6. Late Representations

- 6.1 The Council has adopted the following procedures with respect to the receipt of late representations on planning applications (Planning report PLN 0113 refers):
- a) All properly made representations received **before** the expiry of the final closing date for comment will be summarised in the Committee report. Where such representations are received after the agenda has been published, the receipt of such representations will be reported orally and the contents summarised on the amendment sheet that is circulated at the Committee meeting. Where the final closing date for comment falls **after** the date of the Committee meeting, this will be highlighted in the report and the recommendation caveated accordingly.

- b) Representations from both applicants and others made **after** the expiry of the final closing date for comment and received **after** the report has been published will not be accepted unless they raise a new material consideration which has not been taken into account in the preparation of the report or draws attention to an error in the report.
- c) Representations that are sent to Members should not be accepted or allowed to influence Members in the determination of any planning application unless those representations have first been submitted to the Council in the proper manner (but see (b) above).
- d) Copies of individual representations will not be circulated to members but where the requisite number of copies are provided, copies of individual representation will be placed in Members' pigeonholes.
- e) All letters of representation will be made readily available in the Committee room an hour before the Committee meeting.

7. Financial Implications

- 7.1 There are no direct financial implications arising from this report. However, in the event of an appeal, further resources will be put towards defending the Council's decision. Rarely, and in certain circumstances, decisions on planning applications may result in the Council facing an application for costs arising from a planning appeal. Officers will aim to alert Members where this may be likely and provide appropriate advice in such circumstances.

Keith Holland
Head of Planning

Background Papers

- *The individual planning application file (reference no. quoted in each case)*
- *Rushmoor Core Strategy (2011)*
- *Rushmoor Local Plan Review (1996-2011)[Saved policies]*
- *Current government advice and guidance contained in circulars, ministerial statements and the National Planning Practice Guidance (NPPG)*
- *Any other document specifically referred to in the report.*
- *Regional Spatial Strategy for the South East, policy NRM6: Thames Basin Heaths Special Protection Area.*
- *The National Planning Policy Framework.*
- *Hampshire Minerals and Waste Plan (2013).*

Section A

Future items for Committee

Section A items are for INFORMATION purposes only. It comprises applications that have either been submitted some time ago but are still not yet ready for consideration or are recently received applications that are not ready to be considered by the Committee. The background papers for all the applications are the application details contained in the Part 1 Planning Register.

Item	Reference	Description and address
1	15/00897/REMPP	<p>PART APPROVAL OF RESERVED MATTERS: for the conversion of the Cambridge Military Hospital (including part demolition, extensions and external alterations) to provide 74 dwellings (Use Class C3) and 943m2 of mixed commercial and community uses (Use Classes A3, B1, D1 and D2); with associated landscaping, access and parking, in Development Zone C (Cambridge Military Hospital), pursuant to Condition 4 (1 to 21), attached to Outline Planning Permission 12/00958/OUT dated 10th March 2014.</p> <p>Zone C - Cambridge Military Hospital Aldershot Urban Extension Alisons Road Aldershot</p> <p>This application has only recently been received and consultations are underway.</p>
2	15/00898/REMPP	<p>PART APPROVAL OF RESERVED MATTERS: for the redevelopment of the Louise Margaret Hospital and Nurses Residence (including part demolition, external alterations, extensions and new build) to provide 42 dwellings (Use Class C3) with associated landscaping, access and parking, in Development Zone C (Cambridge Military Hospital), pursuant to Condition 4 (1 to 21), attached to Outline Planning Permission 12/00958/OUT dated 10th March 2014.</p> <p>Zone C - Cambridge Military Hospital Aldershot Urban Extension Alisons Road Aldershot</p> <p>This application has only recently been received and</p>

		consultations are underway.
3	15/00930/LBC2PP	<p>LISTED BUILDING CONSENT: for internal and external alterations, including part demolition, to facilitate the conversion of the Cambridge Military Hospital to provide 74 dwellings and 943m2 of mixed commercial and community uses in Development Zone C (Cambridge Military Hospital).(PLEASE SEE APPLICATION REFERENCE 15/00897/REMPP FOR DRAWINGS AND DOCUMENTS)</p> <p>Zone C - Cambridge Military Hospital Aldershot Urban Extension Alisons Road Aldershot</p> <p>This application has only recently been received and consultations are underway.</p>
4	15/00931/LBC2PP	<p>LISTED BUILDING CONSENT: for internal and external alterations, including part demolition, to facilitate the redevelopment of the Louise Margaret Hospital and Nurses Residence site to provide 42 dwellings, in Development Zone C (Cambridge Military Hospital). (PLEASE SEE APPLICATION REFERENCE 15/00898/REMPP FOR DRAWINGS AND DOCUMENTS)</p> <p>Zone C - Cambridge Military Hospital Aldershot Urban Extension Alisons Road Aldershot</p> <p>This application has only recently been received and consultations are underway.</p>
5	16/00007/FULPP	<p>Development of 14,489sqm (GIA) of industrial/warehouse units with ancillary offices within B1c/B2 and/or B8 Use Classes with associated car/cycle parking, service areas and landscaping</p> <p>Land At Dingley Way Farnborough</p> <p>This application has only recently been received and consultations are underway.</p>
6	16/00027/FUL	<p>Construction of a 'Home Shopping' link canopy and van loading canopy and other associated works.</p> <p>ASDA Westmead Farnborough</p> <p>This application has only recently been received and consultations are underway.</p>

7	16/00133/REMPP	<p>APPROVAL OF RESERVED MATTERS: for 107 Dwellings (87 Flats and 20 houses) in Gunhill (Zone E), pursuant to Condition 4 (1 to 21), attached to Outline Planning Permission 12/00958/OUT dated 10th March 2014 on Land at Wellesley, Aldershot Urban Extension, centred on Queen's Avenue and Alisons Road, Aldershot, Hampshire</p> <p>Zone E - Gunhill Aldershot Urban Extension Alisons Road Aldershot</p> <p>This application has only recently been received and consultations are underway.</p>
---	----------------	------------------------------------------------------------------------------------------------------------------------------------------------------------------------------------------------------------------------------------------------------------------------------------------------------------------------------------------------------------------------------------------------------------------------------------------------------------------------------------------------------------------

Section B

Petitions

Item	Reference	Description and address
		There are no petitions to report

The information, recommendations and advice contained in this report are correct as at the date of preparation, which is more than two weeks in advance of the Committee meeting. Because of these time constraints some reports may have been prepared in advance of the final date given for consultee responses or neighbour comment. Any changes or necessary updates to the report will be made orally at the Committee meeting.

Case Officer	David Stevens
Application No.	16/00049/FULPP
Date Valid	20th January 2016
Expiry date of consultations	17th February 2016
Proposal	Demolition of existing public house and re-development of site with two pairs of 2-bedroom semi-detached houses on road frontage with new access between leading to a pair of 3-bedroom semi-detached houses at rear of site (6 new dwellings in total), together with detached garages, parking spaces, turning area and associated landscaping (re-submission of planning application 15/00475/FULPP refused 18 September 2015)
Address	The Queens Head 97 North Lane Aldershot
Ward	North Town
Applicant	Mr G J & Mrs A Boulden
Agent	Adams Hendry Consulting Limited
Recommendation	GRANT subject to s106 Unilateral Undertaking

Description & Relevant History

The site is located on the west side of North Lane and comprises a vacant Public House with ancillary residential accommodation over. The property has parking in a forecourt area and to the north side of the building, capable of accommodating approximately 15 cars. The rear half of the site is a garden area with a number of trees and shrubs around the margins. The property was acquired by the applicant in August 2013 following closure as a Public House under previous owners in January 2013. The site is currently enclosed on the road frontage by hoardings. The building itself is in multiple occupation comprising six bedsitting rooms with communal facilities on the ground floor and a self-contained flat at first floor. This residential use is occurring without the benefit of planning permission.

The site is of an irregular shape, has an area measuring 0.15 hectares, a road frontage 27 metres wide, and narrows down to a width of 19 metres towards the rear. It is located on the west side of North Lane opposite the commercial units at the Alpha Centre. To the immediate south is No.95 North Lane and the rear garden boundaries of residential properties at Nos.9, 10, 11 and 12 Northfield Close back on to this side boundary further to the rear. The rear (west) boundary of the site backs onto part of the side boundary of the rear garden of No.224

Holly Road. To the north, the site abuts maisonettes and houses at Nos.226-236 Holly Road and Nos.99 and 101 North Lane.

Planning permission was refused in September 2015 for demolition of the existing Public House building and the re-development of the site with a total of six two-storey semi-detached houses, 15/00475/FULPP, for the following reasons:-

- “1 *It has not been satisfactorily demonstrated that there is no longer term need for the Public House and that alternative Public Houses are readily accessible to meet the needs of the community in the vicinity in accordance with the requirements of the Council's "Development Affecting Public Houses" Supplementary Planning Document formally adopted by the Council's Cabinet on 2 June 2015. The proposed development would thereby result in the unjustified loss of a community facility contrary to Government Planning Policy and Guidance and also Policy CP10 of the Rushmoor Core Strategy (November 2011).*
- 2 *The proposal fails to make provision for an appropriate Special Protection Area Mitigation and Avoidance contribution towards the Hawley Meadows suitable accessible natural green space, or strategic access management measures in order to address the impact of the proposed development upon the nature conservation interest and objectives of the Thames Basin Heaths Special Protection Area. The proposal is thereby contrary to the requirements of Policies CP13 and CP15 of the Rushmoor Core Strategy adopted October 2011.*
- 3 *The proposals do not make provision for public open space in accordance with the requirements of Policies CP11 and CP12 of the Rushmoor Core Strategy adopted October 2011, saved Local Plan Policies OR4 and OR4.1; and the Council's continuing Interim Advice Note (dated August 2000 and updated July 2006) "Financial Contributions towards Provision of Open Space in Association with New Housing Development".*”

The current proposal is a re-submission of an almost identical scheme for the site accompanied by additional information in relation to the need for, and viability of, the Public House, thereby seeking to address Reason for Refusal No.1. The applicants are seeking to prepare a s106 Planning Obligation in the form of a Unilateral Undertaking to offer financial contributions towards the off-site provision and/or enhancement of Public Open Space, and in respect of the SPA Mitigation and Avoidance in order to address Reasons nos.2 & 3.

It is proposed to erect two pairs of two-storey 2-bedroom semi-detached houses conventionally fronting North Lane (House Nos.1-4 inclusive), with an access road leading into the site in-between the frontage pairs to a turning area, with a further pair of larger 3-bedroom two-storey semi-detached houses with attached garages (House Nos.5 & 6) located at the rear of the site. House Nos.1-4 inclusive would have detached garages located to the rear.

Each of the proposed houses would be provided with two on-plot parking spaces comprising a garage and forecourt parking space. A pair of visitor parking spaces would be provided within the access road. All of the proposed houses would have private rear garden areas. Due to the set-back of the frontage units from the road, House Nos.1-4 would also have front garden areas.

The proposed houses are of a conventional design with mainly fully-hipped roofs. Each pair of frontage houses would have an asymmetric form, with one half of each pair having a

feature gable-end facing the road. It is indicated that the houses would be finished with brick and have slate roofs.

The application is accompanied by a Planning, Design & Access Statement, a report assessing compliance with the Council's "Development Affecting Public Houses" Supplementary Planning Document, an Arboricultural Report, an Ecological Appraisal, a Surface Water Drainage Strategy Report, and a Sustainability Appraisal.

Consideration of this application was deferred at the meeting of the Development Management Committee on 2 March 2016. This was in order to allow time for the evidence submitted with the application of compliance with the Council's "Development Affecting Public Houses" Supplementary Planning Document to be subject to independent assessment and review by an external consultant experienced in the operation of the pub trade.

Consultee Responses

Transportation Strategy Officer	No highway objections. No Transport Contribution required having taken account of the traffic generation potential of the Public House planning use of the site.
Planning Policy	No objections following receipt of independent consultant's advice.
Environmental Health	As previously, No objections subject to conditions and informatives. Conditions to include a sound insulation condition in respect of the frontage units on account of the impact of road traffic noise from the adjoining road.
Community - Contracts Manager	No objections.
Parks Development Officer	No objections and identifies a project to which Public Open Space contribution would contribute.
Aboricultural Officer	As previously, No objections : no trees worthy of retention would be lost.
Ecologist Officer	As previously, No objections : the submitted Ecological Report is satisfactory and appropriately identifies the need for further surveys of the building prior to demolition; and of the trees/shrubs on site prior to their removal.
Thames Water	No objections.
Hampshire & I.O.W. Wildlife Trust	No comments received during the consultation period, thereby presumed to have no objections.
Environment Agency	No comments made by the EA since they note that the site lies within Flood Zone 1 (land at least risk of flooding) although close to Flood Zone 2 (land at intermediate risk of flooding).
Natural England	No objections provided SPA impact mitigated. Reference is

made to NE Standing Advice in terms of the assessment of the risk of protected species being located at the site.

Crime Prevention Design Advisor

No objections, but comments that, to provide for the safety and security of residents and visitors an appropriate level of lighting should be provided throughout the development.

Hampshire Fire & Rescue Service

No objections and provides generic fire prevention advice.

Aldershot Civic Society

No comments received during the consultation period.

Neighbours notified

In addition to posting a site notice and press advertisement, 31 individual letters of notification were sent to properties in North Lane, Holly Road and Northfield Close, including all properties physically adjoining the site. This total also includes notification letters sent to 5 respondents to the previous application whom do not adjoin the application site.

Neighbour comments

Objections to the proposals have been received from the occupiers of Nos.11 & 12 Northfield Close (directly adjoining the site to the south); 224 Holly Road (partially directly adjoining to the west); and the Pubs Officer for the Surrey Hants Borders Campaign for Real Ale (CAMRA) on the following collective grounds:-

- (a) Despite the submission of additional information, the marketing information submitted with the application remains inadequate and does not in any way satisfy and address the requirements of the Council's newly adopted "Development Affecting Public Houses" SPD;
- (b) It is clear that the Pub was acquired by the current owner with no intention of running the Pub as a going concern;
- (c) It is also clear that no real effort has been made to market the property as a Pub and, indeed, genuine potential purchasers intending to re-open the Pub have been discouraged by the applicant;
- (d) The needs of the local community have not been considered : the Pub has a large potential catchment area given that there are no other Pubs left in North Town;
- (e) There are no other Pubs within a reasonable distance that offer sufficiently similar facilities. The area would benefit from retaining a Pub/restaurant;
- (f) Loss of local amenity and community facility;
- (g) Overdevelopment : too many houses would be crammed onto the site;
- (h) Removal of screening trees adjoining the site boundary [with Nos.11 & 12 Northfield Close] would expose these properties to loss of privacy (including possible overlooking from side-facing landing window [Officer Note: shown to be obscurely glazed] of House No.5) and security against crime/trespass;
- (i) Loss of amenity and privacy in adjoining garden (No.224 Holly Road);
- (j) Increased noise levels; and
- (k) No allowance has been made with the plans for the provision of street lighting : there should be no light spillage into neighbour's adjoining garden areas.

Support for the proposals has been received from the occupiers of Nos.95 and 138 North Lane. They make the following observations:-

- (1) The plan makes good use of space and shows properties designed to be in keeping with those already facing North Lane;
- (2) Parking and Access have been well thought out;
- (3) North Town residents identified their apathy regarding a Public House on this site through the Ward Councillors survey;
- (4) The building is not of any historic interest;
- (5) The current building is in disrepair and has looked a mess for a number of years;
- (6) I have lived opposite for the past 6 years and have seen several different landlords struggle to make it a viable business. It is unlikely to ever open as a pub again;
- (7) Permitting the current scheme would provide much needed, affordable, modest housing with associated car parking; and
- (8) The proposed development can only be a welcome improvement to the local area.

Policy and determining issues

The site is located within the built-up area of Aldershot. It is not in a Conservation Area, nor located adjoining a Listed Building. The building is not identified as a Building of Local Importance as a result of the "Buildings of Local Importance" SPD. Furthermore, despite a community nomination of the property as an "Asset of Community Value" (ACV) under the Localism Act in May 2015, the Solicitor to the Council confirmed by decision dated 2 July 2015 that the property should not be placed on the Council's ACV list. As a result, the property has no status providing any protection from recent permitted development changes.

The Rushmoor Core Strategy was adopted by the Council in October 2011 and, as such, has replaced the Rushmoor Local Plan Review (1996-2011) as being part of the Development Plan for the area. To this end Core Strategy Policies CP1 (Sustainable Development Principles), CP2 (Design and Heritage), CP3 (Renewable Energy and Sustainable Construction), CP4 (Surface Water Flooding), CP5 (Meeting Housing Needs and Housing Mix), CP10 (Infrastructure Provision), CP11 (Green Infrastructure Network), CP12 (Open Space, Sport and Recreation), CP13 (Thames Basin Heaths Special Protection Area), CP15 (Biodiversity), CP16 (Reducing and Managing Travel Demand) and CP17 (Investing in Transport) are relevant to the consideration of the current proposals.

Whilst the Core Strategy introduced new policies replacing specific Local Plan policies, a number of Local Plan policies continue to be 'saved' and therefore remain in use for the time being. In this respect, Local Plan Policies ENV17 (general development criteria), H14 (amenity space), ENV41-43 (flood risk) and OR4/OR4.1 are 'saved' policies that remain relevant to the consideration of this application.

The Council's new adopted Supplementary Planning Document (SPD) "Development Affecting Public Houses" formally adopted by the Council's Cabinet with effect from 30 June 2015 is relevant to the consideration of this application. Also relevant are the Council's adopted SPDs "Housing Density and Design" and "Sustainable Design and Construction" both adopted in April 2006; 'Transport Contributions' adopted in April 2008; and "Parking Standards" adopted in 2012. Since these documents were subject to extensive public consultation and consequent amendment before being adopted by the Council, some significant weight can be attached to the requirements of these documents. The advice contained in the National Planning Policy Framework (NPPF) and National Planning Policy Guidance (NPPG) is also relevant.

Core Strategy Policy CP6 requires, subject to viability, provision of 35% affordable housing with developments of 15 or more net dwellings. However, since the scheme proposes only

six additional units, the requirements of this policy do not apply in this case.

Almost identical proposals were considered by the Council in September 2015 when it was concluded that the proposals be refused, but solely in respect of failure to adequately address the Council's adopted "Development Affecting Public Houses" SPD; and on grounds of the failure of the applicant to complete a s106 to secure SPA and Public Open Space financial contributions. The layout and quantum of development were considered to be acceptable in planning terms. It is therefore necessary to consider whether there have been any material changes in planning circumstances since the previous application was considered in September 2015. In this context, the key determining issues are considered to be:

1. The Principle of the proposals;
2. Design and Visual Impact including impact on trees;
3. Impact on Neighbours;
4. The Living Environment Provided;
5. Highways Considerations;
6. Impact on Wildlife;
7. Drainage Issues;
8. Renewable Energy and Sustainability; and
9. Public Open Space.

Commentary

1. Principle -

Core Strategy Policy CP10 (infrastructure provision) seeks the retention of community facilities unless specific circumstances can be shown to exist. Specifically the policy states that community facilities "...will be protected unless:

- (i) *It can be proven that there is no longer term need for the facility, either for its original purpose or for another facility that meets the need of the community; or*
- (ii) *It is to be re-provided elsewhere to the satisfaction of the Council."*

Although the Policy does not define a public house as being a 'community use', Paragraph 70 of the NPPF states, inter alia, that:-

"To deliver the social, recreational and cultural facilities and services the community needs, planning policies and decisions should:

- *Plan positively for the provision and use of shared space, community facilities (such as shops, meeting places, sports venues, cultural buildings, public houses and places of worship) and other local services to enhance the sustainability of communities and residential environments;*
- *Guard against the unnecessary loss of valued facilities and services, particularly where this would reduce the community's ability to meet its day-to-day needs;"*

The recognition of public houses as a community facility in the NPPF means that any policies in the Rushmoor Plan referring to community facilities should also cover properties in Public House use.

The National Planning Policy and Guidance and Core Strategy Policy CP10 set out the context and justification within which the “Development Affecting Public Houses” SPD has been proposed and adopted by the Council. The SPD sets out a standard and consistent approach for an applicant seeking to demonstrate that there is no longer-term need for the Public House, including a further requirement to demonstrate that alternative Public Houses are readily accessible to serve the needs of the community. These matters must be considered and found acceptable before planning permission can be granted for proposals resulting in the loss of a Public House.

The Queens Head (97 North Lane) is identified as a safeguarded former Pub site, to which the SPD relates.

The current application is a re-submission of a previous application that was refused on the grounds of failing to comply with the requirements of the SPD. Further information has been submitted by the applicants seeking to address this. It comprises an amended ‘Assessment of compliance with Supplementary Planning Document’. This information has been reviewed by an independent external consultant, Voysey Limited Chartered Surveyors, who have experience of licensed, leisure and retail property from a client base including the Pub trade.

Demonstrating no longer term need for the Public House

Marketing Evidence : The Queens Head public house was marketed on Enterprise Inns’ website between January 2011 and September 2012. Independent brokers such as McCoys, Christies, Fleurets and AW Gore were notified regarding the availability of the public house. On the 3rd March 2013, New Ballerino took over the marketing of the site and the following measures were undertaken:

- A For Sale sign was erected on the premises;
- Sales particulars were circulated to registered parties;
- Mail outs to local commercial and residential agents;
- Site included on EG PropertyLink, NOVOLOCA, Showcase, Rightmove and New Ballerino websites.

The freehold of the site was offered for sale on an unconditional basis. Evidence of this is included within Appendix 1 of the Assessment of Compliance document. 25 enquiries were received in respect of the site, including just one enquiry from a potential purchaser within the pub trade.

Following the purchase of the site by the applicants in August 2013, New Ballerino was retained to market the site whilst also exploring alternative uses for the site. 7 further enquiries came forward although no interest was shown in the site as a public house. In addition, a period of discreet marketing was apparently undertaken by Bridges Estate Agents, leading only to enquiries for residential use.

Voysey Ltd is critical of the appointment of New Ballerino as the marketing agent, as they are not a specialist in the licensed property sector, borne out by the statistics they provide that, of the 87 pubs they have sold to date, only 5 continued to be used as public houses. Such a low conversion rate should be compared against that of licensed property sales specialists, whom report at least 50% of their sales of bottom end public houses are for continued pub use. However, Voysey Ltd consider that a property of this nature, if remaining as a public house, is most likely to be purchased by either a locally based investor and/or owner-occupier. Therefore on the basis that local advertising, including the display of a ‘for sale’

board on the property, has been undertaken since the start of November 2015, it is considered that it is most probable that the pool of potential purchasers has been sufficiently targeted by the marketing that has been undertaken.

The marketing undertaken in this respect elicited 6 further queries regarding the potential use of the site. The Assessment of Compliance document suggests that all of these queries were discounted for various reasons. It was brought to the Council's attention that at least one of these enquiries made in December 2015 showed an interest in acquiring the site as a public house. An exchange of emails between this interested party and the landowner has been provided to the Council by the enquirer that indicated that they were keen to inspect the property but did not receive adequate answers to their questions. The Case Officer has sought further information from the applicant's agents and also the enquirer in relation to this enquiry. The applicant has not received any further communication from this enquirer; and the enquirer indicates that they are no longer interested in the property.

The SPD requires copies of all sales literature (and in the case of a signboard, dated photographs) to support a planning application. The difficulty in this instance is that the majority of marketing was undertaken prior to the adoption of the SPD and thus the applicant does not possess all of the details required. Were this requirement to be addressed, the applicant would need to re-market the property in accordance with the criteria of the SPD for a further 12 months. However, given the timing of the adoption of the SPD, and the extent of marketing that has been undertaken previously and the fact that the public house has been out of operation for at least 3 years, the Council's Planning Policy Team are of the view that this would be an unreasonable request; and would further delay any potential re-use of the site. Evidence has been provided that the public house has been subject to marketing since 2011 until its purchase in August 2013 and beyond, with little appetite shown for retaining the existing use. It is also the opinion of the independent review that, on balance, the marketing criteria have been met.

Efforts to preserve the Public House : Evidence has been provided by the applicants showing a decline in annual beer volumes between 2006 and 2012. In addition, Enterprise Inns plc has confirmed that the rent was sub-optimised, and higher than normal discounts on beers were offered in order to obtain interest in the site. Previous tenants of the public house, the Bryants, have provided a statement relating to their management of the property for the period December 2011 to August 2012. During their tenancy, the Bryants advertised in local papers, redecorated the front of house and refitted the kitchen with the aim of picking up food trade. Investment was made in secondary double-glazing in order to address neighbours' noise concerns and a number of events including open mic, live music and an evening restaurant failed to draw in enough customers to make the venture viable. The accounts submitted as part of the current application demonstrate that the public house failed to turn a net profit during the tenancy of the Bryants. They state that the pub was being used by drug abusers and found it quite hard to clean-up. By banning the abusers and undesirable clientele, they were apparently left with little trade. The Planning Policy Team consider that this demonstrates that 'reasonable effort' (as required by the SPD) was made to preserve the public house use by credible publicans with previous experience of the local pub trade.

It should be noted that the situation in 2013 is different to the picture today within North Town. A significant regeneration scheme is well advanced with the demolition of 471 flats to make way for 471 new homes, plus an additional 226 homes with permission. A key aspiration of this venture is to address the deprivation that was associated with the area. This scheme is located within easy walking distance of the Queens Head public house and new housing is complete and occupied. In addition, the closure of the Heroes of Lucknow as a result of a permitted development conversion has improved the relative competitive potential

of the Queens Head. However, whilst this would suggest that the viability of a public house use in this area may possibly have improved since 2013, it also needs to be borne in mind that the public house use has been inactive for over three years and the condition of the property has been affected. New Ballerino declined to take on the re-marketing of the public house on the basis that there would be even less appetite for it as a trading pub because of the extended period of closure. The Fleurets report states that significant capital expenditure would be required to bring the pub back into use. This gives rise to further concerns that the re-use of the site as a public house would not be a viable venture notwithstanding the potential for increased clientele within the catchment and reduced pub competition.

Voysey Limited note that many public houses have historically operated with low levels of sales and profitability; and, as in this case, this may provide an operator with an income below minimum wage rates, or a potential incoming investor with insufficient and high-risk returns. Such pubs may be considered to be unviable. This can be demonstrated by way of financial projections, and whilst the submitted Assessment of Compliance report does not provide these, it is not considered unreasonable to reach the conclusion that the pub is not economically viable based upon the supporting historical information, the very limited interest shown in the purchase of the property, and the reviewer's opinion of profitability based upon market perception.

Demonstrating that alternative public houses are readily available

Evidence has been put forward to demonstrate that five alternative public houses are located within 800 metres of the application property. Details of the facilities within these public houses have been provided and it is apparent that a similar community environment equivalent to that within the former Queens Head is available. The Planning Policy Team has previously raised concern that the loss of the public house would have a detrimental effect on access to pubs from large parts of North Town that would fall outside of the 800m catchment of alternative public houses, thus affecting the community's ability to meet its day-to-day needs. The applicant's supporting statement notes that this is 'regrettable', but argues that there hasn't been a public house to use here since January 2013.

There are no on-going active campaigns by local community groups or 'Friends' groups other than CAMRA in respect of retaining this public house during its period of closure. Furthermore, in late 2015, the North Town Ward Councillors included a survey within the autumn edition of 'North Town Matters', delivered to approximately 3,000 households locally, asking whether they would like to see a pub in North Town. Only 45 survey forms were returned (1.5% return). Despite 93% of respondents saying 'Yes' to a Pub and 83% saying they would use one on a regular basis, this indicates a very limited interest in a pub being re-provided in the North Town area.

In light of the fundamental concerns relating to the viability of the re-use of the pub that have already been identified, it is considered that it would be unreasonable for the Council to seek to refuse an application on the basis that parts of the community would be located outside the 800m catchment of a public house. This factor alone would not serve to bring the site back into use and, indeed, there is little indication that the North Town community would make sufficient use of a re-opened pub on this site to render such a venture economically viable.

In light of the information provided in support of this application and the subsequent independent review undertaken by Voysey Ltd, the Planning Policy Team are satisfied that the criteria of the 'Development affecting Public Houses' SPD have now been adequately addressed and consequently no policy objection is raised to the proposals.

2. Visual Impact -

The vicinity has a mixed character, with a variety of dwelling types, ages and external materials. Nevertheless, there is a predominance of two-storey terraced and semi-detached houses. As a result, it is considered that the proposed frontage houses (Nos.1-4 inclusive) would be sympathetic to the character and appearance of the existing street scene in North Lane. Proposed house Nos.5-6 would be located in a backland position where they would not be particularly visible from publicly accessible vantage points in the street and, even then, at some distance. Nevertheless, it is considered that the design and external appearance of this proposed development would also accord with the already varied design and external appearance of existing development in the locality. In this respect, there has been no change since the previous application was considered last September.

Appropriate quality external finishing and surfacing materials can be secured by imposition of the usual conditions. There is also scope for the introduction of landscape planting to soften the appearance of the development in the street, the internal courtyard and also in respect of adjoining residential properties. Although a number of trees and shrubs around the margins of the site would be removed, none are considered to be worthy of retention having regard to saved Local Plan Policy ENV13. Furthermore, it is not considered that the loss of these trees would have any material and harmful visual impact, especially since there would be opportunities to plant new trees within the scheme.

Accordingly, it is considered that the proposed development would integrate effectively into its surroundings and not significantly detract from the character and appearance of the area. It is therefore considered that the proposals are acceptable in visual terms.

3. Impact on Neighbours -

It is considered that the proposed houses would have entirely conventional relationships with all their neighbours. Due to a combination of house design, orientation and separation distances, it is considered that no undue and unacceptable relationships with neighbouring properties would arise in planning terms.

Although objection has been raised on grounds of loss of privacy in respect of Nos.11 and 12 Northfield Close, this concern relates to the side-facing landing window of House No.5 that is shown to be obscurely-glazed; and the plans submitted with the current planning application have been amended to highlight this. Objection has now also been raised by the occupiers of No.224 Holly Road (whom were notified but did not make representations in respect of the previous application) on grounds of loss of privacy. However this adjoining property abuts the site for the rear half of their rear garden only, with the rear elevation of the Plot 5 & 6 houses facing perpendicularly towards with a separation distance of 8.5 metres. Further, these proposed houses are specifically designed to reduce the number of first floor windows facing the rear : there is a small dormer bedroom window and a high-level en-suite for each proposed house only. In the circumstances it is considered that the impact upon the amenities of occupiers of No.224 Holly Road would be insufficient to justify the refusal of planning permission and is, thereby, acceptable in planning terms.

The usual planning conditions can be imposed to ensure that the obscure glazing is installed and retained; and for no further windows to be installed in the side and rear first floor elevations or roofs of the proposed houses.

Although objection has been raised about the potential impact of any street lighting within the

proposed development, there is no planning requirement for any lighting to be provided, notwithstanding the suggestion of the Police Crime Prevention Advisor. The access road and turning head within the scheme would not be adopted highway and, as such, remain a private road, such that it is considered unlikely that lighting would be provided. Nevertheless, to cover the possibility that the developer may wish to provide some form of lighting externally within the scheme for security purposes, it is considered appropriate for this to be dealt with by the submission of details pursuant to a condition.

4. Living Environment Created -

Each of the proposed dwellings would be provided with private rear gardens sufficient to provide an acceptable living environment. The internal layout of a development is a functional matter between a developer and his client and is to some extent covered by the Building Regulations. It is therefore a matter for prospective purchasers/occupiers to decide whether they choose to live in the proposed development. Nevertheless, it is considered that the living environment created would be acceptable.

5. Highways Considerations -

Since the existing lawful use of the site is as a Public House on a site capable of accommodating approximately 15 cars, the traffic generation potential for this use is the base position from which to consider the highways impact of the proposed development. In this respect, the proposed access arrangements to the site involve creation of a new road access junction onto North Lane positioned centrally within the site road frontage. This would replace the existing arrangement where vehicles could enter or leave the road at almost any position along the site frontage depending upon the extent/pattern of use of the on-site parking. The proposed access would have acceptable visibility sightlines. The proposed access road is of acceptable dimensions and has adequate visibility splays. The internal design and layout of the site is also considered to be acceptable. The Transportation Strategy Officer is also satisfied that the traffic associated with the proposed development would have no material and harmful impact on traffic conditions on North Lane.

The proposed houses would each be provided with two parking spaces each, together with provision of two on-site visitor spaces. All would be of acceptable size, on-site location and arrangement. This provision meets the Council's adopted maximum parking standards in full and, as such, the proposed development makes appropriate provision for parking on-site to support itself. Cycle parking would be provided by sheds in the rear gardens of each of the proposed dwelling plots.

The refuse/recycling bins for each property would be stored on each individual plot with this arrangement and simply moved by residents to the collection point when required. This is the usual way in which bins are collected for emptying and, as such, it is considered to be an acceptable arrangement for the proposed development. Sheds are shown to be provided to provide on-plot cycle storage for each individual plot.

The Council's Transportation Strategy Officer has confirmed that no Transport Contribution can be justified in this case given that the proposed development is considered likely to generate less traffic than would arise from the resumption of the Public House use.

It is considered that the proposals are acceptable in highways terms.

6. Impact on Wildlife -

The Rushmoor Thames Basin Heaths Special Protection Area Interim Avoidance and Mitigation Strategy comprises two elements. Firstly the maintenance of Suitable Alternative Natural Greenspace (SANG) at Hawley Meadows in order to divert additional recreational pressure away from the Thames Basin Heaths Special Protection Area (TBHSPA) and secondly the maintenance of a range of Strategic Access Management and Monitoring Measures to avoid displacing visitors from one part of the TBHSPA to another and to minimize the impact of visitors on the TBHSPA. The proposal meets the criteria against which requests to allocate capacity at the Hawley Meadows SANG will be considered.

The applicant is aware of this requirement and the need to make a financial contribution of £35,766 to maintain the Hawley Meadows SPA mitigation scheme to be secured by way of a section 106 planning obligation. In this respect the applicant has contacted the Council's Legal Team to pursue this matter. Natural England raises no objection to proposals for new residential development in the form of Standing Advice provided that it is in accordance with the above strategy. Provided the applicants submit a satisfactory completed s106 Undertaking by no later than 4 April 2016 it is considered that they would have satisfactorily mitigated for the impact of their proposed development on the Thames Basin Heaths Special Protection Area in compliance with the requirements of Core Strategy Policies CP11 and CP13.

According to the submitted Ecological Survey report there some potential for protected wildlife species existing or likely to exist at the application site that would be affected by the proposed development. The Report therefore correctly identifies the need for surveys to be undertaken prior to demolition or tree/shrub removal works being undertaken to ascertain whether any such protected species are present at that time. The Council's Ecology & Biodiversity Officer considers this approach to be appropriate. Accordingly, on a precautionary basis, were the Council minded to grant planning permission, this would be subject to an informative advising the applicant of the requirements of the Wildlife & Countryside Act with respect to any protected wildlife species encountered on site.

7. Surface Water Drainage –

The proposed development is considered likely to result in an improvement in the surface water drainage situation despite the additional hard-surfacing that would occur as a result of the additional building. The applicants indicate that a SUDs system would be incorporated to deal with surface water drainage on site. Accordingly it is considered appropriate to deal with this matter through the imposition of a condition requiring the submission of details of the system to be installed and how this would be maintained. The site is located within Flood Zone 1, which is land at the lowest risk of flooding. As a result, the Environment Agency raise no objections as standing advice and no mitigation measures are indicated as being necessary. This being the case, it is considered that there is no requirement under Policy CP4 for mitigation measures to be incorporated into the development. Accordingly, subject to the imposition of a condition to require the submission of details in this respect, it is considered that the requirements of Core Strategy Policy CP4 would be met.

8. Sustainable Development and Renewable Energy -

The application, is accompanied by a sustainability assessment to address the requirements of Policy CP3. However following the Royal Assent of the Deregulation Bill 2015 (on 26 March 2015) the government's current policy position is that planning permissions should no longer be granted requiring or subject to conditions requiring compliance with any technical housing standards such as the Code for Sustainable Homes. This is other than for those areas where Councils have existing policies referring to the attainment of such standards. In

the case of Rushmoor this means that we can require energy performance in accordance with Code Level 4 as set out in policy CP3 of the Rushmoor Core Strategy. Such measures may be secured by way of condition and on this basis no objection is raised to the proposal in terms of Policy CP3.

9. Public Open Space -

The Local Plan seeks to ensure that adequate open space provision is made to cater for future residents in connection with new residential developments. Core Strategy Policy CP10 and saved Local Plan Policies OR4 and OR4.1 allow provision to be made on the site, or in appropriate circumstances, a contribution to be made towards upgrading facilities nearby. The policy does not set a threshold of a particular number of dwellings or size of site above which the provision is required. The site is not big enough to accommodate anything other than the development proposed and any associated landscape planting.

This is a circumstance where a contribution (in this case £7,330.20 towards the off-site provision of public open space comprising: playground refurbishment at Aspen Grove, Aldershot) secured by way of a planning obligation in the form of a Unilateral Undertaking would be appropriate. Subject to the applicant satisfactorily completing and submitting the s106 Undertaking in this respect no later than 11 March 2016, it is considered that the proposal would be acceptable within the terms of Core Strategy Policies CP10, CP11 and CP12 and saved Local Plan Policy OR4. However failure to do so would result in a further reason for refusal being advanced on the grounds of the scheme not addressing the requirements of Core Strategy Policies CP10, CP11 and CP12 and saved Local Plan Policy OR4.

Conclusions : Following an independent review of the material submitted with the application seeking to address the Council's adopted 'Development Affecting Public Houses' SPD, it is considered that the reasons for refusal of the 2015 appeal scheme have been satisfactorily addressed as a result of the additional information submitted with the current scheme. The proposals are therefore considered to be acceptable in principle, would have no material and harmful impact upon the visual character and appearance of the area, have no material and adverse impact on neighbours, would provide an acceptable living environment, and, are acceptable in highway terms. On the basis of the provision of a contribution towards the Hawley Meadows SPA mitigation and avoidance scheme, the proposals are considered to have no significant impact upon the nature conservation interest and objectives of the Thames Basin Heaths Special Protection Area. On the basis of the provision of a contribution towards the enhancement of existing public open space in the vicinity of the site, the proposals are considered to comply with the Council's policies concerning provision and enhancement of public open space. The proposals are thereby considered acceptable having regard to Policies SS1, CP1, CP2, CP5, CP10, CP11, CP12, CP13, CP15, CP16, and CP17 of the Rushmoor Core Strategy and saved Local Plan Policies ENV13, ENV17, ENV41-43, TR10, OR4/OR4.1 and H14.

FULL RECOMMENDATION

It is recommended that subject to the completion of a satisfactory Agreement under Section 106 of the Town and Country Planning Act 1990 by 4 April 2016 to secure appropriate financial contributions towards open space and SPA mitigation, the Head of Planning in consultation with the Chairman be authorised to **GRANT** planning permission subject to the following conditions and informatives:-

However, in the event that a satisfactory s106 Agreement is not received by 4 April 2016 the Head of Planning, in consultation with the Chairman, be authorised to refuse planning permission on the grounds that the proposal does not make satisfactory provision for public open space in accordance with Core Strategy Policies CP10, CP11 and CP12 and saved Local Plan Policy OR4; and a financial contribution to mitigate the effect of the development on the Thames Basin Heaths Special Protection Area in accordance with the Rushmoor Thames Basin Heaths Special Protection Area Interim Avoidance and Mitigation Strategy and Core Strategy Policies CP11 and CP13.

- 1 The development hereby permitted shall be begun before the expiration of one year from the date of this permission.

Reason - As required by Section 91 of the Town and Country Planning Act 1990 as amended by Section 51 of the Planning and Compulsory Purchase Act 2004, to reflect the objectives of the Council's Thames Basin Heaths Special Protection Area Avoidance and Mitigation Strategy as amended July 2014 and to accord with the resolution of Rushmoor's Cabinet on 17 June 2014 in respect of Planning Report no PLN1420.

- 2 Unless agreed in writing by the Local Planning Authority, the permission hereby granted shall be carried out in accordance with the following approved drawings – LJS Architects Drawing Nos.A546/501A, -/510A, -/511A, -/512, -/515A, -/516A, -/517A, and -/518A; Martin J Harvey Drawing Nos.L6-02-01 and L6-02-02; and Ian Keen Ltd. Drawing Nos.8784/01 and 8784/02 Rev.A.

Reason - To ensure the development is implemented in accordance with the permission granted.

- 3 No works shall start on site until a schedule and/or samples of the external materials to be used in the development have been submitted to, and approved in writing by, the Local Planning Authority.

Reason - To ensure satisfactory external appearance.*

- 4 No works shall start on site until a schedule and/or samples of surfacing materials, including those to access driveways/forecourts to be used in the development have been submitted to, and approved in writing by, the Local Planning Authority.

Reason - To ensure satisfactory external appearance and drainage arrangements.*

- 5 The development hereby approved shall be undertaken in accordance with the details of the existing and proposed ground levels shown on approved plan Martin J Harvey Drawing No.L6-02-01.

Reason - To ensure a satisfactory form of development in relation to neighbouring property.

- 6 No works shall start on site until details of all screen and boundary walls, fences, hedges or other means of enclosure have been submitted to and approved in writing by the Local Planning Authority. The development shall be completed and retained in accordance with the details so approved.

Reason - To safeguard the amenities of neighbouring property.*

- 7 Notwithstanding the provisions of the Town and Country Planning (General Permitted Development Order) 2015, (or any Order revoking and re-enacting that Order), no development falling within Classes, A, B, and C of Part 1 of Schedule 2 shall be carried out without the prior permission of the Local Planning Authority.

Reason - To protect the amenities of neighbouring residential properties.

- 8 Notwithstanding the provisions of the Town and Country Planning (General Permitted Development Order) 2015, (or any Order revoking and re-enacting that Order), no additional windows, doors or openings of any kind shall be inserted in the side elevations or roofspace of the development hereby permitted without the prior permission of the Local Planning Authority. Furthermore, there shall be no alteration of the size and positions of the windows shown to be provided on the plans hereby approved.

Reason - To protect the amenities of neighbouring properties.

- 9 Construction or demolition work of any sort within the area covered by the application shall only take place between the hours of 0800-1800 on Monday to Fridays and 0800-1300 on Saturdays. No work at all shall take place on Sundays and Bank or Statutory Holidays.

Reason - To protect the amenities of neighbouring residential properties and to prevent adverse impact on traffic and parking conditions in the vicinity.

- 10 No works shall start on site until a fully detailed landscape and planting scheme (to include, where appropriate, both landscape planting and ecological enhancement) has been submitted to and approved in writing by the Local Planning Authority.

Reason - To ensure the development makes an adequate contribution to visual amenity.*

- 11 All planting, seeding or turfing comprised in the approved details of landscaping shall be carried out in the first planting and seeding season following the occupation of the buildings or the practical completion of the development, whichever is the sooner, and any trees or plants which within a period of 5 years from the completion of the development die, are removed or become seriously damaged or diseased shall be replaced in the next planting season with others of similar size and species, unless otherwise first agreed in writing by the Local Planning Authority.

Reason - In the interests of amenity and to help achieve a satisfactory standard of landscaping.

- 12 The development hereby approved shall not be occupied until the off-street parking facilities shown on the approved plans (including the garage parking spaces) have been completed and made ready for use by the occupiers. The parking facilities shall be thereafter retained solely for parking purposes to be used by the occupiers of, and visitors to, the development as indicated on the approved plans. For the avoidance of doubt the parking spaces shall not be used for the parking or storage of boats, caravans or trailers.

Reason - To ensure the provision and availability of adequate off-street parking.

- 13 Provision shall be made for services to be placed underground. No overhead wire or cables or other form of overhead servicing shall be placed over or used in the development of the application site.

Reason - In the interests of visual amenity.

- 14 The cycle parking facilities and refuse bin storage/collection area(s) hereby approved shall thereafter be implemented in full before any part of the development is occupied and retained thereafter for their respective purposes as approved.

Reason - In the interests of amenity and to ensure a more satisfactory form of development.

- 15 No other construction works shall be commenced on site until the proposed improvements to the vehicular access to the site and unobstructed sight-lines have been implemented in full as shown on the plans hereby approved. The works so undertaken and sight-lines provided shall be retained thereafter at all times.

Reason – In the interests of the safety and convenience of highway users.

- 16 No works shall start on site until existing trees to be retained on and/or adjoining the site have been adequately protected from damage during site clearance and works, in accordance with the details that are hereby approved with the application. Furthermore, no materials or plant shall be stored and no buildings erected within the protective fencing without the prior consent in writing of the Local Planning Authority.

Reason - To ensure that existing trees are adequately protected in the interests of the visual amenities of the site and the locality in general.

- 17 In the event that unforeseen ground conditions or materials which suggest potential or actual contamination are revealed at any time during implementation of the approved development it must be reported, in writing, immediately to the Local Planning Authority. A competent person must undertake a risk assessment and assess the level and extent of the problem and, where necessary, prepare a report identifying remedial action which shall be submitted to and approved in writing by the Local Planning Authority before the measures are implemented. Following completion of measures identified in the approved remediation scheme a verification report must be prepared and is subject to approval in writing by the Local Planning Authority.

Reason - To ensure that the site is safe for the development permitted and in the interests of amenity and pollution prevention.

- 18 Prior to the first occupation of any of the dwellings hereby permitted, details of measures to achieve the energy performance standards in accordance with Code Level 4 of the Code for Sustainable Homes or equivalent for each of the dwellings hereby permitted shall be submitted to and approved in writing by the Local Planning Authority. Such details as may be approved shall be implemented in full prior to the first occupation of the dwelling(s) to which they relate and retained in perpetuity.

Reason - To reflect the objectives of Policy CP3 of the Rushmoor Core Strategy.

- 19 The proposed windows located in the upper floor side elevations of the dwellings hereby permitted shall be fitted with fixed obscure glass which shall be installed prior to the first occupation of the development and retained thereafter at all times.

Reason – To accord with the proposals as submitted and in the interests of amenity and privacy of neighbouring properties.

- 20 Prior to the commencement of development details of measures to incorporate Sustainable Drainage Systems (SUDS) into the new built development shall be submitted to and approved in writing by the Local Planning Authority. Such details as may be approved shall be implemented in full prior to the first occupation of the newly built residential units and retained in perpetuity.

Reason - To reflect the objectives of Policy CP4 of the Rushmoor Core Strategy. *

- 21 No works shall start on site until details of provision for the parking and turning on site of operatives and construction vehicles during the construction and fitting out works have been submitted to and approved in writing by the Local Planning Authority and the measures so approved shall be implemented throughout the construction period.

Reason - To protect the amenities of neighbouring residential properties and to prevent adverse impact on highway conditions in the vicinity.*

INFORMATIVES

- 1 **INFORMATIVE - REASONS FOR APPROVAL** - The Council has granted permission because:-

Following an independent review of the material submitted with the application seeking to address the Council's adopted 'Development Affecting Public Houses' SPD, it is considered that the reasons for refusal of the 2015 appeal scheme have been satisfactorily addressed as a result of the additional information submitted with the current scheme. The proposals are therefore considered to be acceptable in principle, would have no material and harmful impact upon the visual character and appearance of the area, have no material and adverse impact on neighbours, would provide an acceptable living environment, and, are acceptable in highway terms. On the basis of the provision of a contribution towards the Hawley Meadows SPA mitigation and avoidance scheme, the proposals are considered to have no significant impact upon the nature conservation interest and objectives of the Thames Basin Heaths Special Protection Area. On the basis of the provision of a contribution towards the enhancement of existing public open space in the vicinity of the site, the proposals are considered to comply with the Council's policies concerning provision and enhancement of public open space. The proposals are thereby considered acceptable having regard to Policies SS1, CP1, CP2, CP5, CP10, CP11, CP12, CP13, CP15, CP16, and CP17 of the Rushmoor Core Strategy and saved Local Plan Policies ENV13, ENV17, ENV41-43, TR10, OR4/OR4.1 and H14.

It is therefore considered that subject to compliance with the attached conditions, and taking into account all other material planning considerations, including the provisions of the development plan, the proposal would be acceptable. This also includes a consideration of whether the decision to grant permission is compatible with the Human Rights Act 1998.

- 2 INFORMATIVE - Your attention is specifically drawn to the conditions marked *. These condition(s) require the submission of details, information, drawings etc. to the Local Planning Authority BEFORE WORKS START ON SITE or, require works to be carried out BEFORE COMMENCEMENT OF USE OR FIRST OCCUPATION OF ANY BUILDING. Failure to meet these requirements is in contravention of the terms of the permission and the Council may take enforcement action to secure compliance. As of April 2008 submissions seeking to discharge conditions or requests for confirmation that conditions have been complied with must be accompanied by the appropriate fee.
- 3 INFORMATIVE - This permission is subject to a planning obligation under Section 106 of the Town and Country Planning Act 1990 (as amended).
- 4 INFORMATIVE – In connection with the requirements of Condition No.15, the planning permission hereby granted does not authorise the applicant, or his agents, to construct a new/altered access to, or other work within, the public highway. A separate consent for works within the highway must first be obtained from the highway authority who may be contacted at the following address:- Hampshire County Council Highways Sub Unit, M3 Motorway Compound, Hook, Hampshire, RG27 9AA.
- 5 INFORMATIVE - The applicant is recommended to achieve maximum energy efficiency and reduction of Carbon Dioxide emissions by:
 - a) ensuring the design and materials to be used in the construction of the building are consistent with these aims; and
 - b) using renewable energy sources for the production of electricity and heat using efficient and technologically advanced equipment for the production of electricity and heat.
- 6 INFORMATIVE - The applicant is advised to contact the Recycling and Waste Management Section at Rushmoor Borough Council on 01252 398164 with regard to providing bins for refuse and recycling. The bins should be:
 - 1) provided prior to the occupation of the properties;
 - 2) compatible with the Council's collection vehicles, colour scheme and specifications;
 - 3) appropriate for the number of occupants they serve;
 - 4) fit into the development's bin storage facilities.
- 7 INFORMATIVE - No materials produced as a result of site preparation, clearance, or development should be burnt on site. Please contact the Head of Environmental Health & Housing for advice.
- 8 INFORMATIVE - Measures should be taken to prevent mud from vehicles leaving the site during construction works being deposited on the public highway throughout the construction period.
- 9 INFORMATIVE - The applicant is advised that during the construction phase of the development measures should be employed to contain and minimise dust emissions, to prevent their escape from the development site onto adjoining properties. For further information, please contact the Head of Environmental Health.
- 10 INFORMATIVE - It is a legal requirement to notify Thames Water of any proposed connection to a public sewer. In many parts of its sewerage area, Thames Water provides separate public sewers for foul water and surface water. Within these areas a dwelling should have separate connections: a) to the public foul sewer to carry

waste from toilets, sinks and washing machines, etc, and b) to public surface water sewer for rainwater from roofs and surface drains. Mis-connections can have serious effects: i) If a foul sewage outlet is connected to a public surface water sewer this may result in pollution of a watercourse. ii) If a surface water outlet is connected to a public foul sewer, when a separate surface water system or soakaway exists, this may cause overloading of the public foul sewer at times of heavy rain. This can lead to sewer flooding of properties within the locality. In both instances it is an offence to make the wrong connection. Thames Water can help identify the location of the nearest appropriate public sewer and can be contacted on 0845 850 2777.

- 11 INFORMATIVE - In the UK all species of bats are protected under Schedule 5 of the Wildlife and Countryside Act 1981 (as amended) and under Schedule 2 of the conservation (Natural Habitats & c) Regulations 2004. Other species are also subject to statutory protection. The grant of planning permission does not supersede the requirements of this legislation and any unauthorised works would constitute an offence. If bats or signs of bats, or any other protected species, are encountered at any point during development then all works must stop immediately and local Natural England office and Rushmoor Borough Council must be informed.
- 12 INFORMATIVE - The applicant is requested to bring the conditions attached to this permission to the attention of all contractors working or delivering to the site, in particular any relating to the permitted hours of construction and demolition; and where practicable to have these conditions on display at the site entrance(s) for the duration of the works.
- 13 INFORMATIVE - The Local Planning Authority's commitment to working with the applicants in a positive and proactive way is demonstrated by its offer of pre-application discussion to all, free of charge, and assistance in the validation and determination of applications through the provision of clear guidance regarding necessary supporting information or amendments both before and after submission, in line with the National Planning Policy Framework.

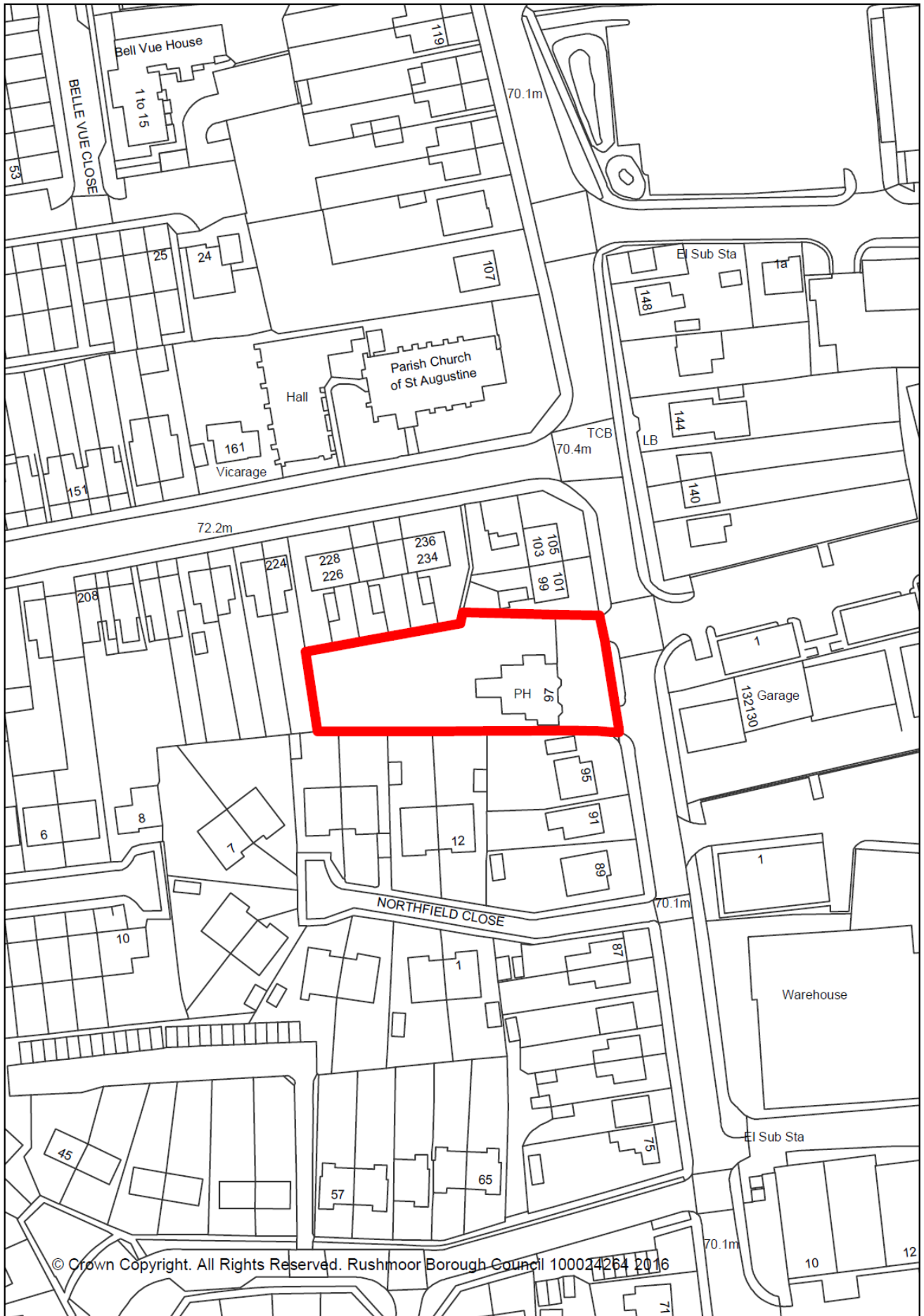



REFUSE & RECYCLING
Each house provided with paving area in garden for bins and temporary bin standing areas near highway for collection

PARKING
1 parking space and 1 garage for each house
2 visitor parking spaces
Storage for 2 cycles in each garage
Visitor's cycle security hoops

Rev A Site boundary revised 22/12/15



Sunnyside Captains Green Road
Yorkley Lydney GL15 4TW
Telephone 01594 564032
email sunnyside@lpsarchitects.co.uk

Client	Mr G Boulden
Project	Six dwellings at 97 North Lane, Aldershot
	Block plan with sight lines
June 2015	1:500 @ A3
	A546/511 A

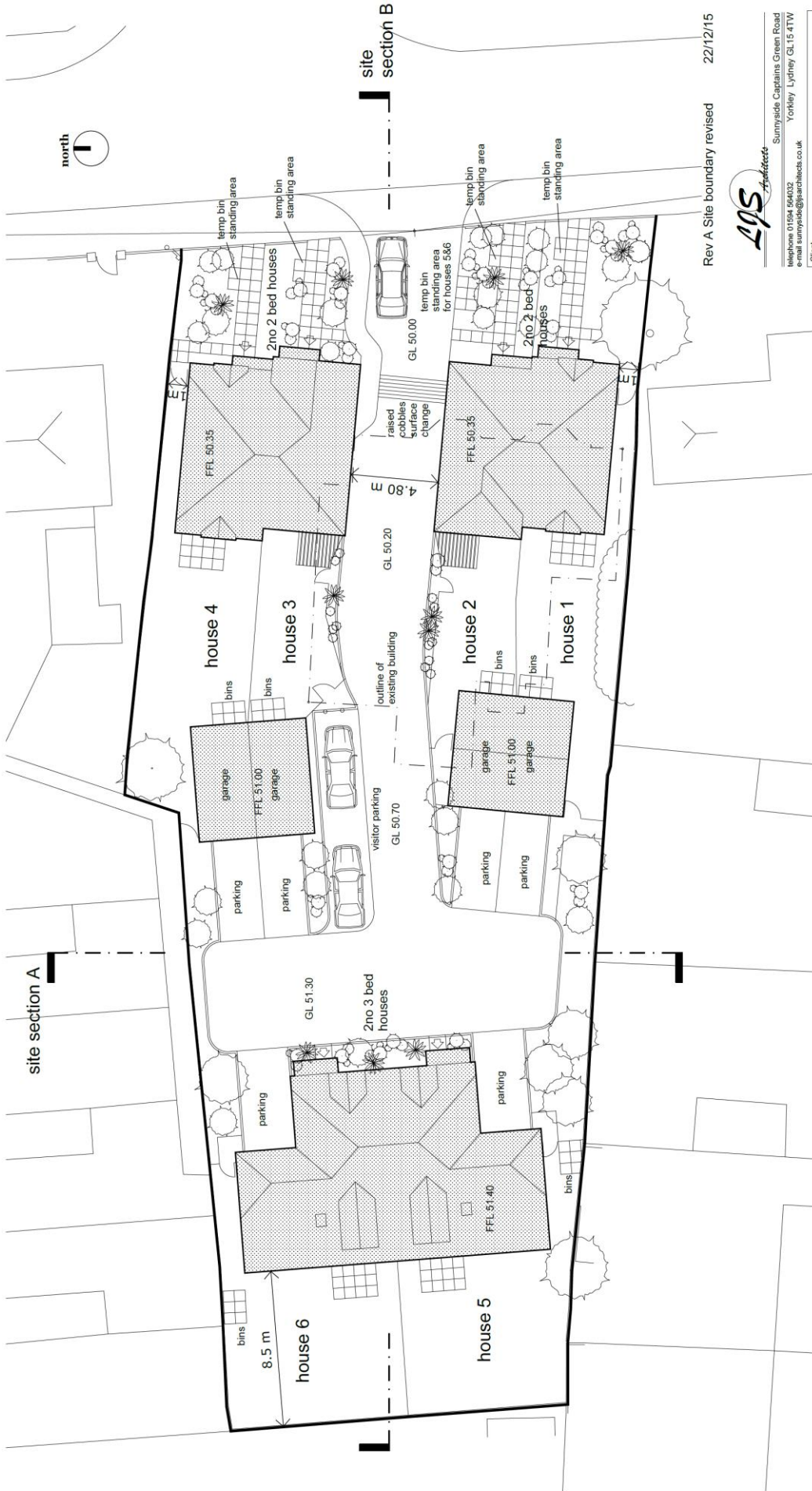

Rev A Site boundary revised 22/12/15



Sunnyside Captains Green Road
 Yorkley Lynhey GL15 4TW
 Telephone 01934 564022
 Email sunnyside@apsarchitects.co.uk

Client	Mr G Boulden
Project	Six dwellings at 97 North Lane, Aldershot
	Site plan
	June 2015
	1:200 @ A3
	A546/510 A

Houses 5 & 6
 Floor area each house 96.9 sq m
 Ground floor 45.5 sq m
 First floor 51.4 sq m
 built-in storage sq m 2.92 sq m
 Technical Housing Standards 2015
 space requirement 3b5p min. 93 + 2.5 = 95.5 sq m

Houses 1 - 4
 Floor area each house 72 sq m
 Ground floor 36 sq m
 First floor 36 sq m
 built-in storage 2.14sq m
 Technical Housing Standards 2015
 space requirement 2b3p min. 70 + 2 = 72 sq m



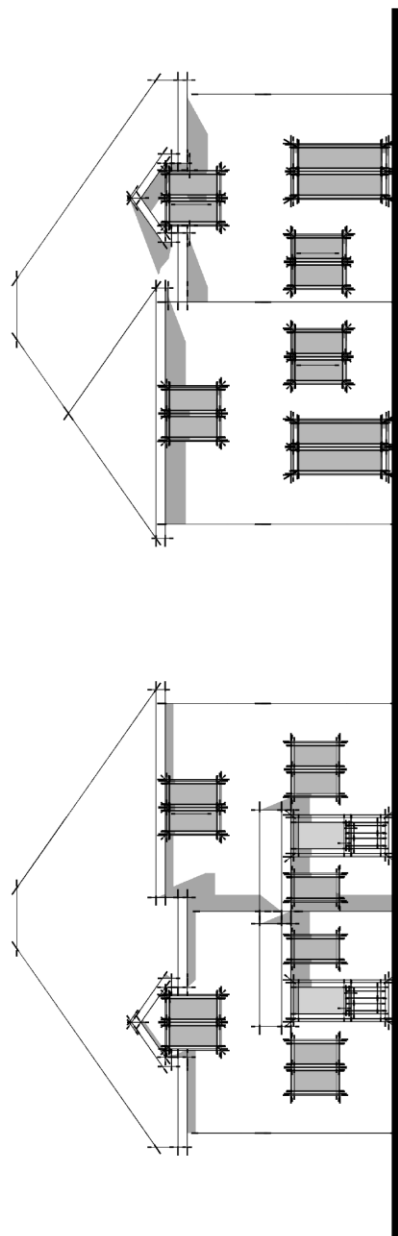

REAR

FRONT

FIRST FLOOR

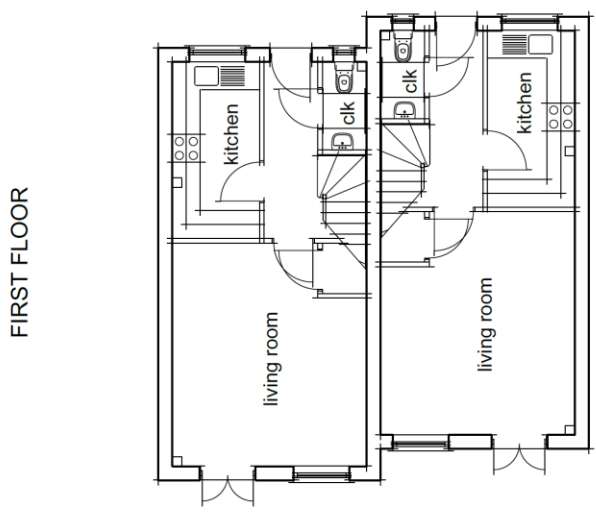
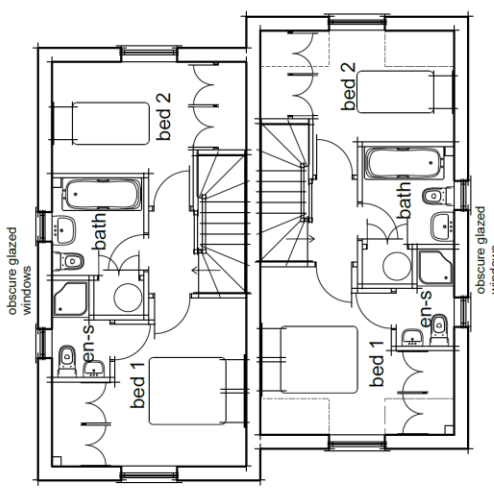

GROUND FLOOR

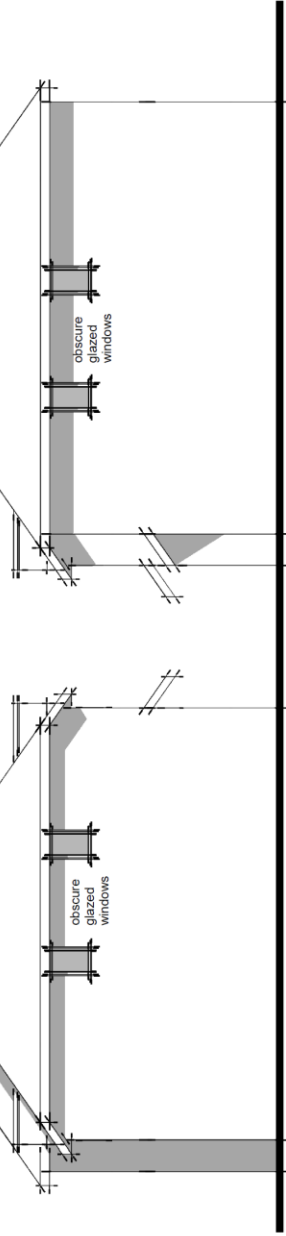

SIDE

SIDE

Rev A Obscure glazing added 22/12/15



Sunnyside Captains Green Road
 Telephone 01594 554032
 e-mail sunnyside@lysarchitects.co.uk

Client	Mr G Boulden
Project	Six dwellings at 97 North Lane, Aldershot
	Houses 1 & 2
June 2015	1:100 @ A3
A546/515A	

Houses 1 - 4
 Floor area each house 72 sq m
 Ground floor 36 sq m
 First floor 36 sq m
 built-in storage 2.14sq m
 Technical Housing Standards 2015
 space requirement 2b3p min. 70 + 2 = 72 sq m



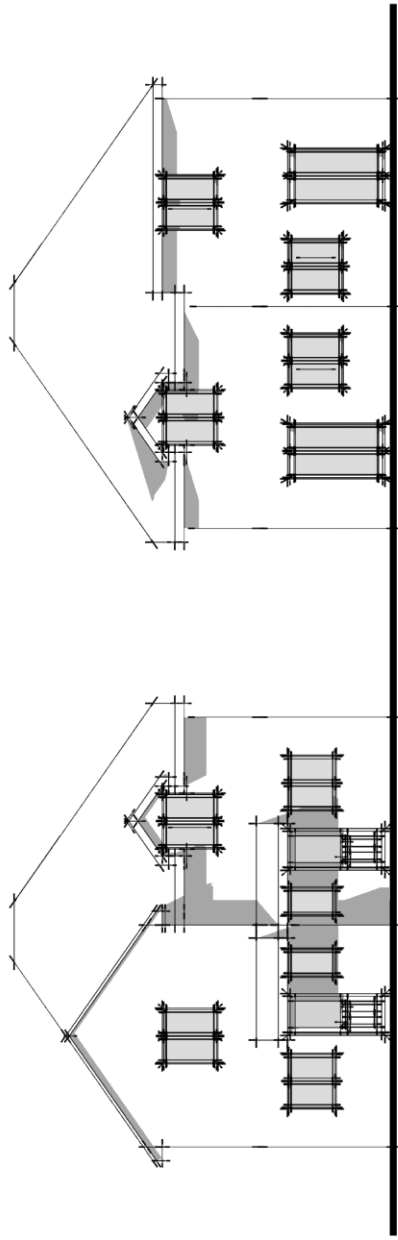

REAR

FRONT

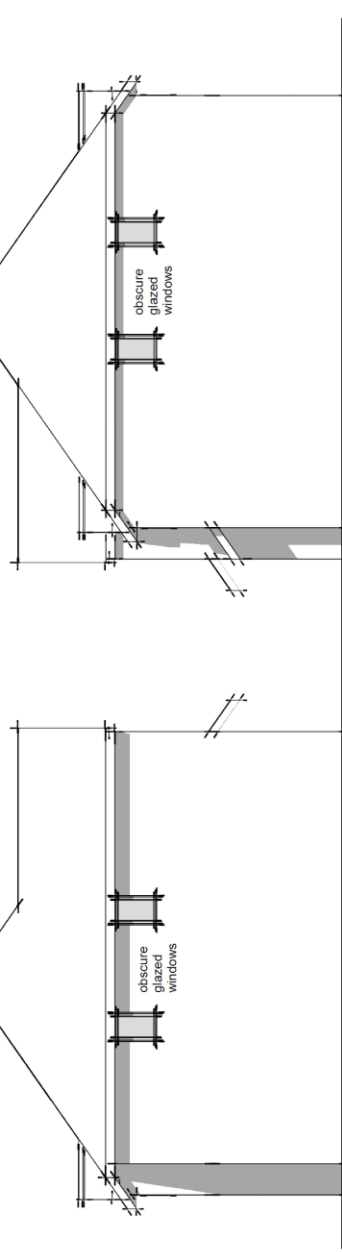

SIDE

SIDE

Rev A Obscure glazing added 22/12/15



Sunnyside Captains Green Road
Yorkley, Lydney, GL15 4TW
telephone 01594 564032
e-mail sunnyside@lpsarchitects.co.uk

Client
Mr G Boulden

Project
Six dwellings at
97 North Lane, Aldershot

Houses 3 & 4

June 2015 1:100 @ A3

A546/516 A ©

Houses 1 - 4
Floor area each house 72 sq m
Ground floor 36 sq m
First floor 36 sq m
built-in storage 2.14sq m
Technical Housing Standards 2015
space requirement 2b3p min. 70 + 2 = 72 sq m

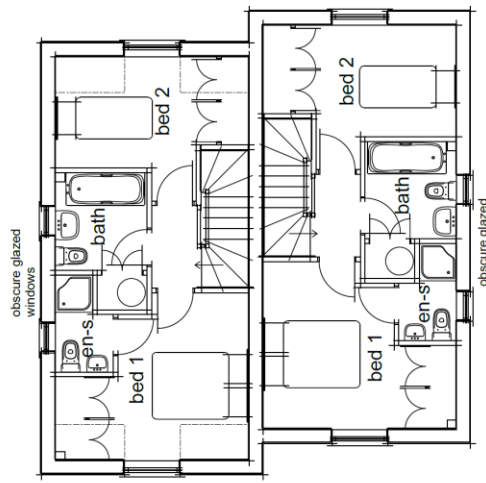

FIRST FLOOR

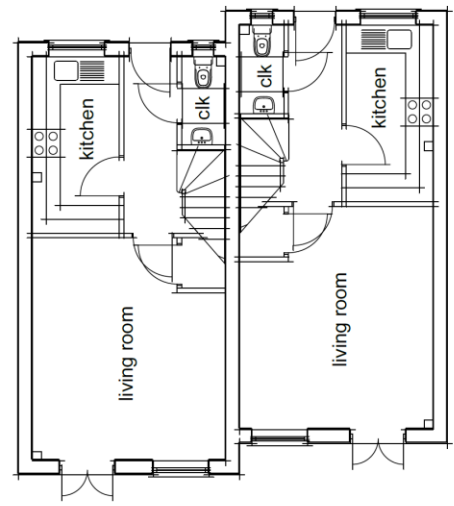

GROUND FLOOR

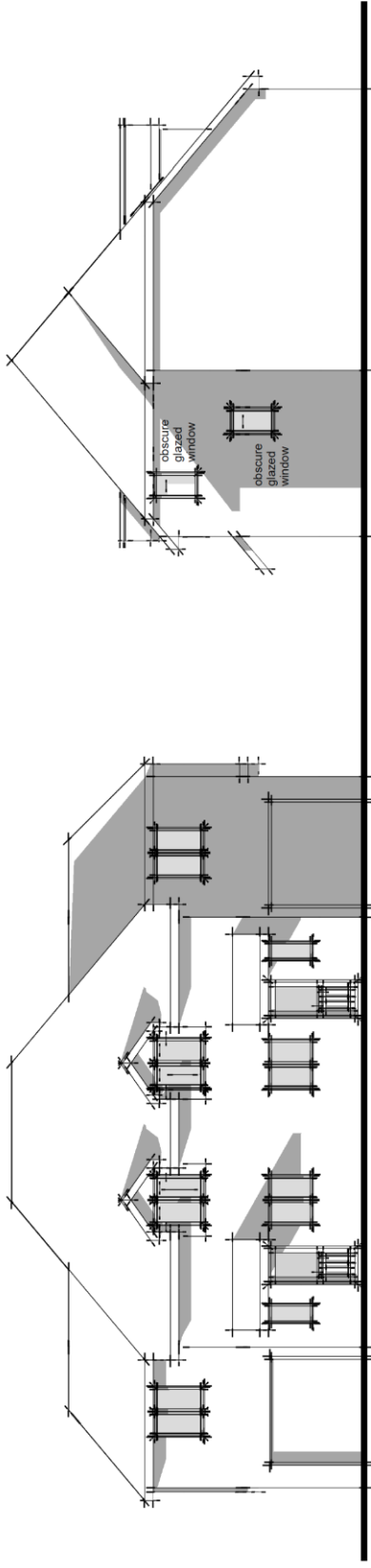

FRONT

SIDE

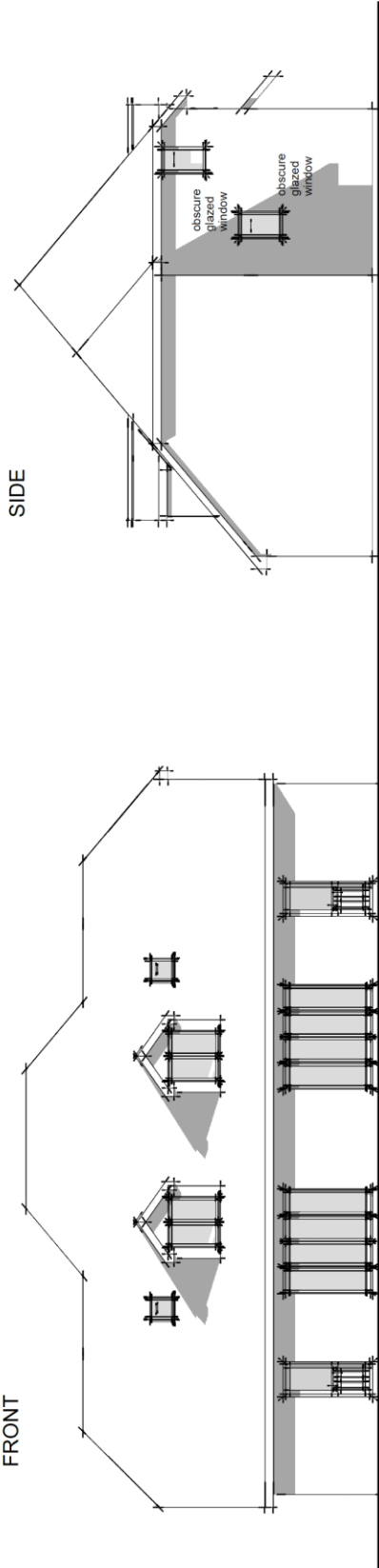

REAR

SIDE

Rev A Obscure glazing added 22/12/15

LPS Architects
 Sunnyside Captains Green Road
 Telephone 01194 564032 Yorkley Lydney GL15 4TW
 Email sunnyside@lpsarchitects.co.uk
 Client

Client	Mr G Boulton
Project	Six dwellings at 97 North Lane, Aldershot
	Houses 5 & 6 Elevations
June 2015	1:100 @ A3
A546/518A ©	



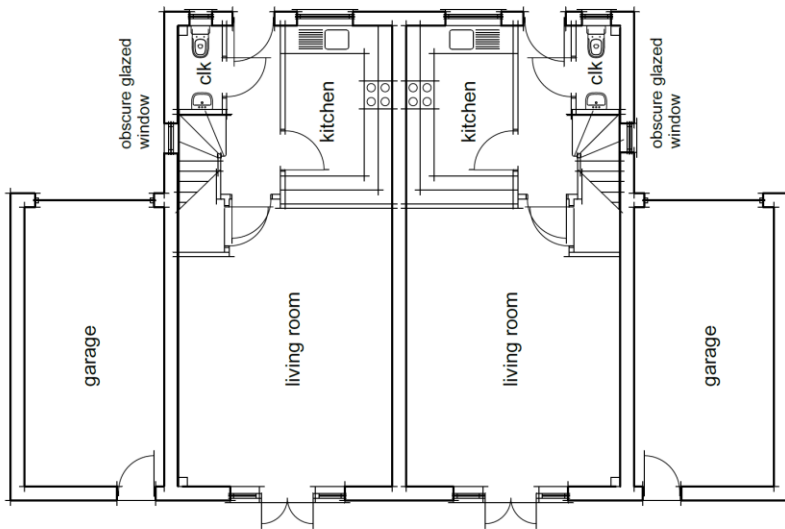

GROUND FLOOR

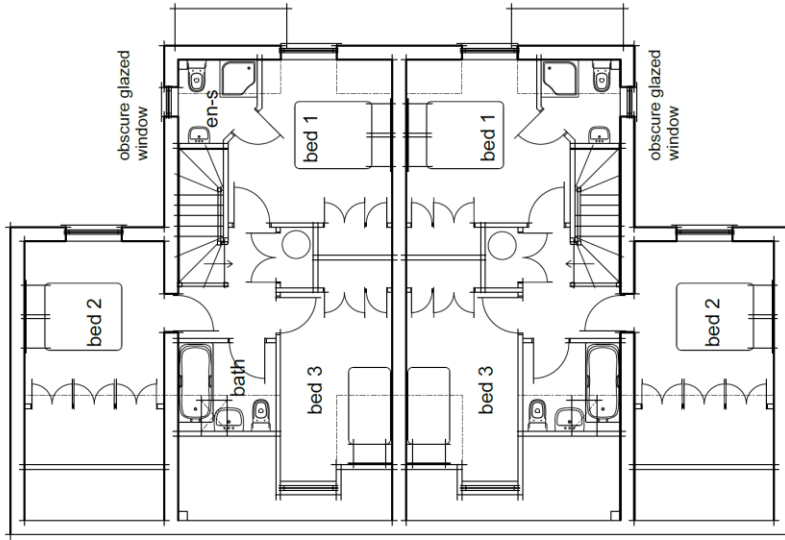

FIRST FLOOR

Houses 5 & 6
 Floor area each house 96.9 sq m
 Ground floor 45.5 sq m
 First floor 51.4 sq m
 Built-in storage sq m 2.92 sq m
 Technical Housing Standards 2015
 space requirement 3b5p min. 93 + 2.5 = 95.5 sq m



Rev A Obscure glazing added 22/12/15



Sunnyside Captains Green Road
 Yorkley Lydney GL15 4TW
 telephone 01594 554032
 e-mail sunnysid@lpsarchitects.co.uk

Client

Mr G Boulden

Project
 Six dwellings at
 97 North Lane, Aldershot

Houses 5 & 6 Plans

June 2015 1:100 @ A3

A546/517 A ©

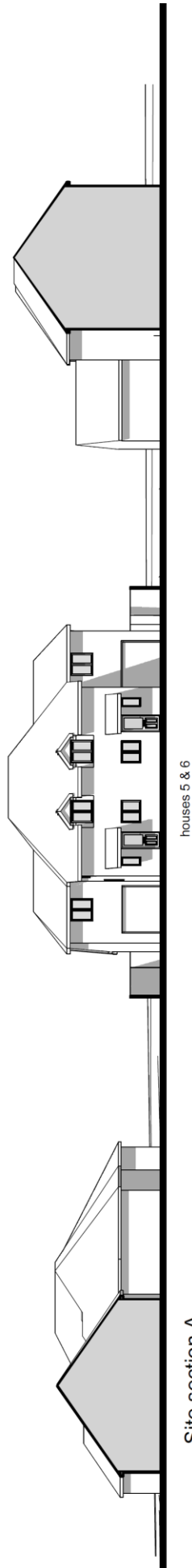

Site section A

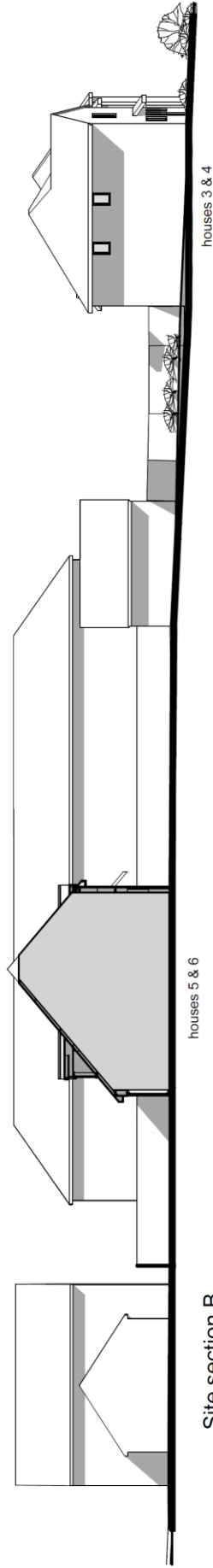

Site section B



Sunnyside Captains Green Road
 Yorkley Lydney GL15 4TW
 Telephone 01594 564032
 e-mail sunnyside@lpsarchitects.co.uk
 Client:

Mr G Boulden

Project Six dwellings at
 97 North Lane, Aldershot

Site sections

June 2015 1:200 @ A3

A546/512

©

The information, recommendations and advice contained in this report are correct as at the date of preparation, which is more than two weeks in advance of the Committee meeting. Because of these time constraints some reports may have been prepared in advance of the final date given for consultee responses or neighbour comment. Any changes or necessary updates to the report will be made orally at the Committee meeting.

Case Officer	Mark Andrews
Application No.	16/00097/FUL
Date Valid	10th February 2016
Expiry date of consultations	2nd March 2016
Proposal	Erection of detached early years classroom building with toilets and group rooms
Address	St Josephs Roman Catholic Primary School Bridge Road Aldershot Hampshire GU11 3DD
Ward	Manor Park
Applicant	Mr Bill James
Recommendation	GRANT

Description

The application site is St Josephs Roman Catholic Primary School and is occupied by a number of school buildings. The site is located to the south of Bridge Road, east of the London to Alton railway, with residential properties of Boxalls Grove immediately to the south and the rear garden boundaries of residential properties on Highfield Avenue to the east.

Planning permission was granted in June 2012 (Ref 12/00320/FUL) for a level all-weather playing pitch, 60m long and 40m wide, with associated fencing, under-pitch drainage and 8 lights mounted on six, 5m high posts. Retrospective planning consent was granted in February 2014 (ref 13/00921/FUL) for the retention of 8 flood lights mounted on six, 10m high columns sited around the perimeter of the all-weather playing pitch.

Planning permission was refused (Ref 15/00964/FUL) by the Development Management Committee of 2nd March 2016, for the erection of 3 single storey extensions to provide 3 classrooms, a single storey hall extension and a detached single storey teaching block to provide 3 early years classrooms for the following reason:

The application has failed to demonstrate that car parking capacity, either on local streets within a reasonable distance of the school, or in off-street parking areas under the control of the school; can be made available and secured in the long term sufficient to accommodate the additional demand and vehicular activity which would result from the proposed expansion in pupil and teacher numbers. The development would therefore give rise to detrimental traffic and parking conditions on the

surrounding highway contrary to the requirements of Core Strategy Policy CP16.

The current application is solely for the erection of the detached 'early years' teaching block which was one of the five elements within the previously refused application. This building would accommodate existing early years students and would be sited south of the main school building, north of the hard play area and east of the main school playground. The building would measure 24.6m wide, 15.98m deep and would have a mono-pitched roof to a maximum height of 4.1m. The building would contain three classrooms, two toilets and two group rooms. The former early years classrooms within the school would be converted into a dance studio to support the school's performing arts curriculum and would provide an additional group room for existing pupils currently being taught within a school corridor.

Consultee Responses

Transportation Strategy Officer	No objection
Arboricultural Officer	No objection
Environmental Health	No objection, subject to condition
Planning Policy	No objection
Hampshire Fire & Rescue Service	No comments received
Rushmoor Access Group	No comments received
Thames Water	No objection
South East Water	No comments received

Neighbours notified

In addition to posting a site notice and press advertisement, 67 individual letters of notification were sent to properties in the vicinity of the application site in Boxalls Grove; Bridge Road; Eggars Hill; Highfield Avenue; Hillside Road and Sheridan Close.

Neighbour comments

To date 3 responses have been received, from the occupiers of 'Kalamara' Bridge Road, 9 Sheridan Close and 14 Sheridan Close. Objections are raised on the following grounds:-

- The proposal will exacerbate existing traffic congestion;
- The roads cannot facilitate any further traffic and would likely result in highway safety issues;
- The proposal will exacerbate existing illegal/inconsiderate parking issues during school drop-off and pick-up;
- The group rooms may in the future be used as additional classrooms;
- The school site is no longer fit for purpose and should the school wish to extend student numbers further it would be better that a new site not located so closely to residential areas was sought for the school to re-locate to;
- Given the other applications seen to expand the school, this appears to be an

expansion by stealth and would create issues previously raised in respect of safety and parking;

Policy and determining issues

The site is located within the built up area as defined in the Rushmoor Core Strategy and saved Rushmoor Local Plan Review 1996-2011. As such, Core Strategy Policies CP1 (Sustainable Development Principles), CP2 (Design and Heritage), CP4 (Surface Water Flooding), CP9 (Skills and Training) and CP16 (Reducing and Managing Travel Demand) and saved Local Plan Policy ENV16 (development on major sites) are relevant to the consideration of this proposal, as is the advice contained in the National Planning Policy Framework (NPPF).

The main determining issues are the principle of the proposal, the visual impact, the impact on the amenity of nearby residents, impacts on trees worthy of retention, drainage issues and highway safety considerations.

Commentary

1. Principle –

The school site is located within the defined built up area of Aldershot where there is a presumption in favour of development subject to usual planning considerations (see below). Rushmoor Core Strategy Policy CP9 supports development for educational opportunities by providing improvements to primary schools facilities.

Having regard to the above, it is considered that the proposed development is acceptable in principle.

2. Visual Impact –

The proposed developments would be located within an enclosed site and would not be readily visible from a publically accessible place. The proposed building is considered to be conventional in design and appearance and subject to the use of suitable external materials, is considered to have an acceptable visual impact on the character of the school and the surrounding area.

3. Impact on Neighbours –

Due to the distance of separation, the proposed development is not considered to result in any overlooking, loss of light or over shadowing issues with any neighbouring properties. The Council's Environmental Health Department has been consulted and are satisfied that the internal noise environment of the proposed classrooms is sufficient to satisfy the requirements of the Building Regulations and BB93 (the required guidelines for a satisfactory teaching environmental with regards to noise). Environmental Health are also satisfied that the proposed insulation will be sufficient to ensure that noise from normal classroom activities will be adequately attenuated and will not therefore adversely impact on neighbouring properties and therefore raise no objection.

Having regard to the above, it is considered that the proposed development will have an acceptable impact on the amenity of neighbouring properties.

4. Impact on Trees

The school contains no trees covered by group or individual Tree Preservation Orders (TPO). The site however contains a group of mature and semi-mature Oak trees located on an embankment south of the school buildings and hard surfaced play area and north of the school playing field. Due to the proximity of the trees to the proposed prefabricated early years detached teaching block, the applicant has submitted an Arboricultural Impact Assessment & Method Statement Report, which assess the impact of the development on the embankment Trees. The Council's Arboricultural Officer has been consulted and is satisfied that the proposal would not result in any significant detrimental impact on trees worthy of retention, subject to the imposition of a condition to require the submission and approval of a site specific construction method statement to ensure adequate tree protection measures throughout the development and therefore raises no objection.

Having regard to the above, the proposals are considered to have an acceptable impact on the trees worthy of retention.

5. Drainage Issues –

Core Strategy Policy CP4 requires all new buildings to incorporate Sustainable Drainage Systems (SUDS) with the aim of returning runoff rates and volumes back to the original greenfield discharge to prevent flooding and to ensure the quality of local water. The applicant has submitted some information that indicates it may be possible via a series of interconnected geo-cells, although the information is incomplete. If members are minded to grant planning permission, it is considered that this matter could be dealt with by means of planning condition.

6. Highway Safety Concerns –

The Council's Transportation Strategy Officer has been consulted and raises the following comments;

It is understood that the proposal is to construct a new building for the existing Early Years pupils that attend the school and will not involve any increase in pupil and staff numbers attending the school and therefore no change to the existing number of multi-modal trips.

The applicant has confirmed that one existing Early Years Classrooms would be converted into a small dance studio to support our performing Arts curriculum and group room to accommodate gifted and talented groups that are currently being taught in a corridor. This would appear to indicate that this proposal will not increase the numbers of the school roll and should not then place any further demand on parents cars dropping off or picking. No highway objection.

Having regard it the above, it is considered that the proposal would not result in significant harm to highway safety and is therefore acceptable in highway terms.

Full Recommendation

It is recommended that permission be **GRANTED** subject to the following conditions:

- 1 The development hereby permitted shall be begun before the expiration of three years from the date of this permission.

Reason - As required by Section 91 of the Town and Country Planning Act 1990 as amended by Section 51 of the Planning and Compulsory Purchase Act 2004.

- 2 The permission hereby granted shall be carried out in accordance with the following approved drawings – PLAN-01, PLAN-02, 16614A and 16614B

Reason - To ensure the development is implemented in accordance with the permission granted

- 3 Construction or demolition work of any sort within the area covered by the application shall only take place between the hours of 0800-1800 on Monday to Fridays and 0800-1300 on Saturdays. No work at all shall take place on Sundays and Bank or Statutory Holidays.

Reason - To protect the amenities of neighbouring residential properties and to prevent adverse impact on traffic and parking conditions in the vicinity.

- 4 No development, including demolition works, shall start on site until an Arboricultural Method Statement (AMS)/and scheme of arboricultural supervision detailing low impact methods of construction and other tree protection measures within any tree protection area has been submitted to and approved in writing by The Local Planning Authority. The development shall be carried out strictly in accordance with the details so approved.

Reason - To ensure the amenity value of the tree(s) and shrubs in the vicinity of the development is maintained.*

- 5 No works shall start on site until a schedule and/or samples of the external materials to be used in the development have been submitted to, and approved in writing by, the Local Planning Authority. The Development shall be completed and retained in accordance with the details so approved.

Reason - To ensure satisfactory external appearance.*

- 6 Prior to the commencement of development details of measures to incorporate Sustainable Drainage Systems (SUDS) into the development or suitable alternative drainage strategy shall be submitted to and approved in writing by the Local Planning Authority. Such details as may be approved shall be implemented in full prior to the first occupation of the dwelling and retained in perpetuity.

Reason - To reflect the objectives of Policy CP4 of the Rushmoor Core Strategy _

Informatives

- 1 **INFORMATIVE - REASONS FOR APPROVAL-** The Council has granted permission because the proposal would be acceptable in principle, would have an acceptable impact on the character of the area and on the amenity of neighbouring properties. The proposal is considered to have an acceptable impact on trees worthy of retention, the local water environment and is would not result in any significant harm to highway safety. It is therefore considered that subject to compliance with the attached conditions, and taking into account all other material planning considerations, including the provisions of the development plan, the proposal would be acceptable.

This also includes a consideration of whether the decision to grant permission is compatible with the Human Rights Act 1998

- 2 INFORMATIVE The scheme of arboricultural supervision required pursuant to condition 4; shall make provision for a pre-commencement site meeting between the Council's Arboriculturist, the Developer and their appointed Arboricultural Supervisor to agree matters of detail. It shall specify the frequency of arboricultural monitoring and reporting to the Local Planning Authority on the status of all tree protection measures throughout the course of the development and make provision for the submission and approval of a satisfactory arboricultural completion statement on completion of the whole development, or of specified phases to be agreed.
- 3 INFORMATIVE - Your attention is specifically drawn to the conditions marked *. These condition(s) require the submission of details, information, drawings etc. to the Local Planning Authority BEFORE WORKS START ON SITE or, require works to be carried out BEFORE COMMENCEMENT OF USE OR FIRST OCCUPATION OF ANY BUILDING. Development started, carried out or occupied without first meeting the requirements of these conditions is effectively development carried out WITHOUT PLANNING PERMISSION. The Council will consider the expediency of taking enforcement action against any such development and may refer to any such breach of planning control when responding to local searches. Submissions seeking to discharge conditions or requests for confirmation that conditions have been complied with must be accompanied by the appropriate fee.
- 4 INFORMATIVE - The applicant is reminded that the premises should be made accessible to all disabled people, not just wheelchair users, in accordance with the duties imposed by the Equality Act 2010. This may be achieved by following recommendations set out in British Standard BS 8300: 2009 "Design of buildings and their approaches to meet the needs of disabled people - Code of Practice". Where Building Regulations apply, provision of access for disabled people to the premises will be required in accordance with Approved Document M to the Building Regulations 2000 "Access to and use of buildings". The Rushmoor Access Group would welcome the opportunity to give further advice and guidance.
- 5 INFORMATIVE – The Local Planning Authority's commitment to working with the applicants in a positive and proactive way is demonstrated by its offer of pre-application discussion to all, free of charge, and assistance in the validation and determination of applications through the provision of clear guidance regarding necessary supporting information or amendments both before and after submission, in line with the National Planning Policy Framework.

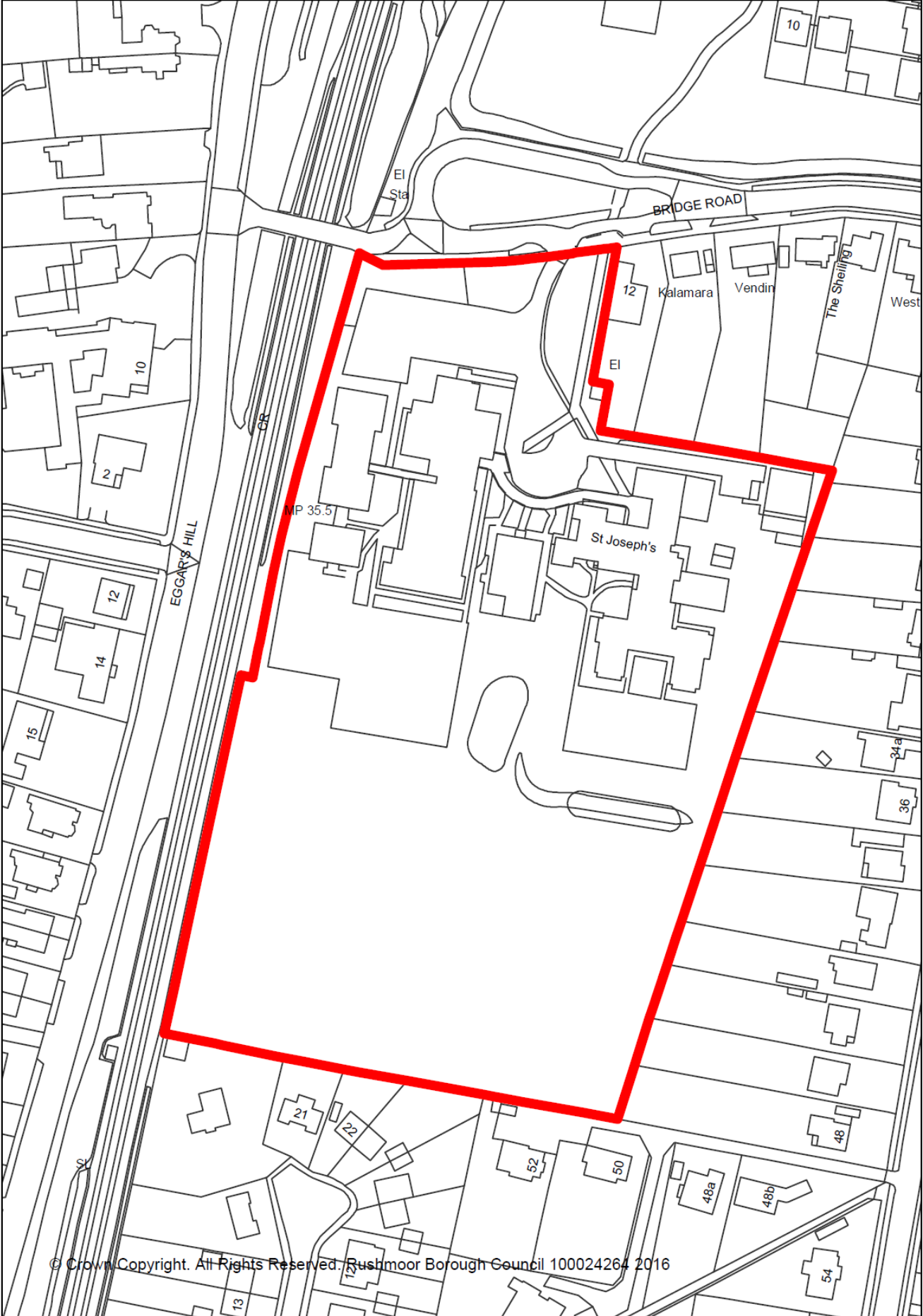

© Crown Copyright. All Rights Reserved. Rushmoor Borough Council 100024264 2016

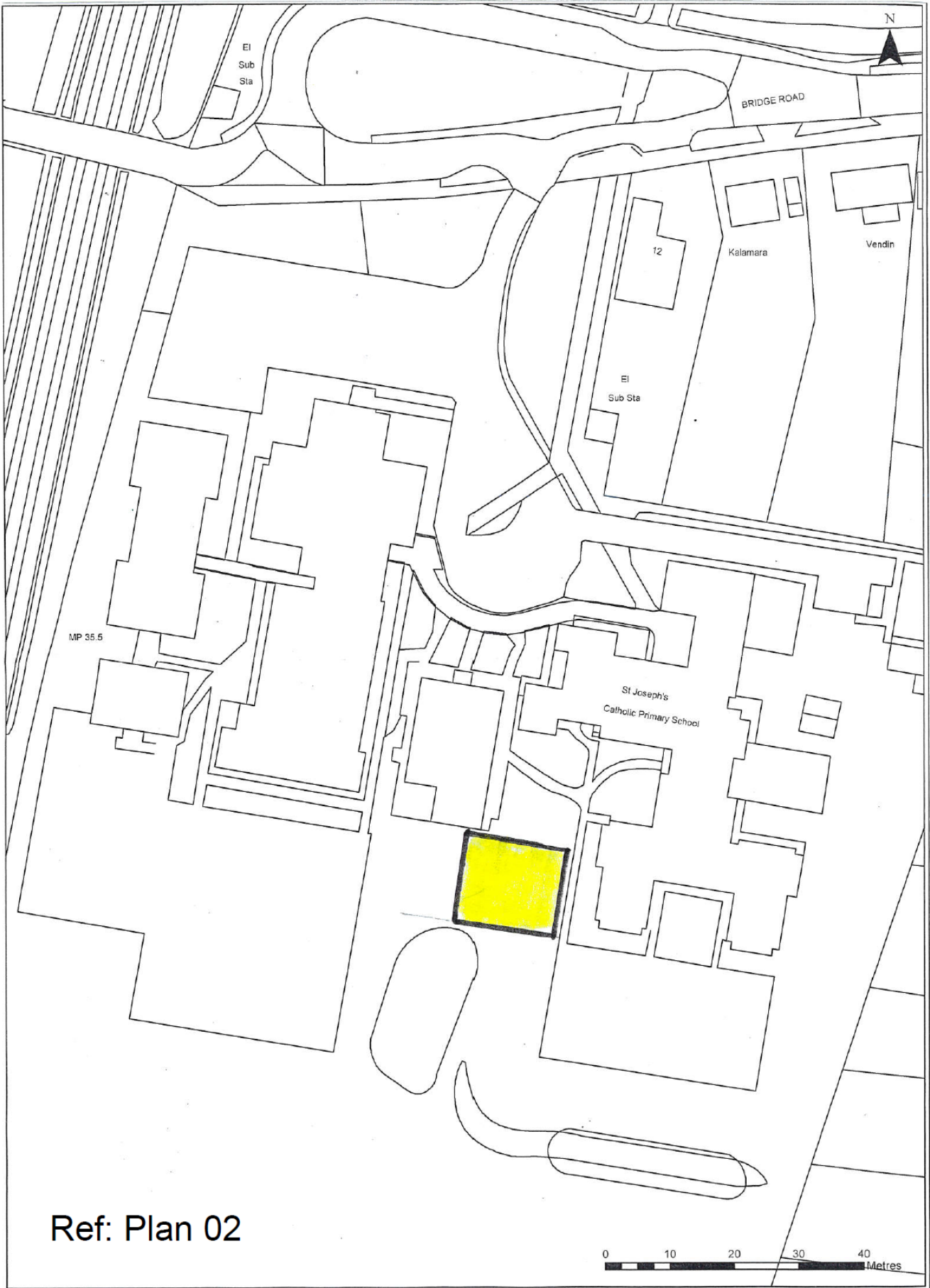

Ref: Plan 02

DESIGNING APPROVAL Form of Approval	
DESIGN	DATE
DESIGN	DATE
DESIGN	DATE
DESIGN	DATE

NOTES:

1. The Contractor shall ensure that all work is completed in accordance with the approved drawings and the specification.

2. Any deviations from the approved drawings shall be notified to the Client in writing and shall be approved by the Client in writing before the work is carried out.

3. The Contractor shall ensure that all work is completed in accordance with the approved drawings and the specification.

4. The Contractor shall ensure that all work is completed in accordance with the approved drawings and the specification.

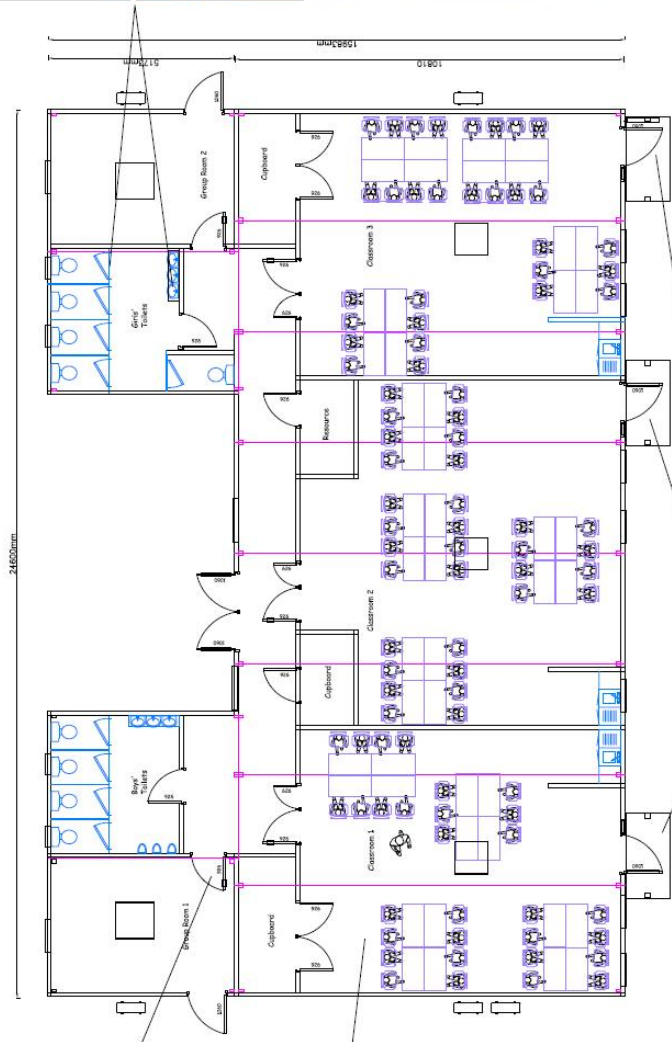

Pictures are indicative of the finish
Furniture is not included

NO.	DESCRIPTION	QTY	UNIT	PRICE
1	RECEPTION	1	SQ M	100
2	CLASSROOM	3	SQ M	150
3	LIBRARY	1	SQ M	150
4	RECEPTION	1	SQ M	100
5	CLASSROOM	3	SQ M	150
6	LIBRARY	1	SQ M	150
7	RECEPTION	1	SQ M	100
8	CLASSROOM	3	SQ M	150
9	LIBRARY	1	SQ M	150
10	RECEPTION	1	SQ M	100
11	CLASSROOM	3	SQ M	150
12	LIBRARY	1	SQ M	150
13	RECEPTION	1	SQ M	100
14	CLASSROOM	3	SQ M	150
15	LIBRARY	1	SQ M	150
16	RECEPTION	1	SQ M	100
17	CLASSROOM	3	SQ M	150
18	LIBRARY	1	SQ M	150
19	RECEPTION	1	SQ M	100
20	CLASSROOM	3	SQ M	150
21	LIBRARY	1	SQ M	150
22	RECEPTION	1	SQ M	100
23	CLASSROOM	3	SQ M	150
24	LIBRARY	1	SQ M	150
25	RECEPTION	1	SQ M	100
26	CLASSROOM	3	SQ M	150
27	LIBRARY	1	SQ M	150
28	RECEPTION	1	SQ M	100
29	CLASSROOM	3	SQ M	150
30	LIBRARY	1	SQ M	150

Springfield
Manufacturers of Quality Accommodation

Head Office:
100 HARRINGTON ROAD
STURTON
LEICESTERSHIRE
LE16 7LU

www.springfield.co.uk
Proposed Early Years Building
Bishop Cleeve
Alderhot

DATE: 15.01.18
SCALE: 1:50

The information, recommendations and advice contained in this report are correct as at the date of preparation, which is more than two weeks in advance of the Committee meeting. Because of these time constraints some reports may have been prepared in advance of the final date given for consultee responses or neighbour comment. Any changes or necessary updates to the report will be made orally at the Committee meeting.

Case Officer	Sarita Jones
Application No.	15/00925/FULPP
Date Valid	4th December 2015
Expiry date of consultations	17th March 2016
Proposal	Redevelopment of existing 'surplus' car park to provide 10 apartments (4 one bed and 6 two bedroom) with associated car and cycle parking, landscaping, amenity space, bin storage and vehicular access from Sarah Way.
Address	Land Off Sarah Way, To The Rear Of 49-51 Victoria Road Farnborough Hampshire
Ward	Empress
Applicant	Farnborough JV LP
Agent	Mr James Lloyd
Recommendation	GRANT subject to s106 Unilateral Undertaking

Description

This irregular shaped site is located to the rear of York House 49-51 Victoria Road, a four storey former office building which has recently been converted into flats. The application site comprises the residual office parking spaces which were left following the residential conversion of the frontage building. The site is generally level. The site has two existing vehicular access points, both of which are from the parking area of York House which is entered from Sarah Way, an adopted public highway to the south. There are no trees of amenity value within the site. 35 Clockhouse Road, a detached single storey dwelling, lies to the north as does one of the car parking areas serving Pipers Patch, a cul-de-sac of flats which takes access from Clockhouse Road. The existing boundary treatment between the site and these properties consists of a variety of fencing, parts of which require attention. 39 Clockhouse Road, a detached bungalow, and 7a Elmgrove Road, one half of a pair of semi-detached houses lie to the west. There appears to be a strip of unclaimed land between the application site and these properties. York House 49-51 Victoria Road lies to the south and contains 23 flats with 23 parking spaces to the rear taking access from Sarah Way. 13-27 Pipers Patch lie to the east and consists of a three storey block of flats. On-street parking controls are in operation in Elmgrove Road and Clockhouse Road. Sarah Way also provides access to the car parking areas to the rear of 43-45, 55 and 61-65 Victoria Road, all of which are currently in office use (see reference below to 61-65 Victoria Road).

In July 1988 planning permission, RSH4848/1, was granted for the demolition of the existing buildings and erection of a four storey office building with car parking to the rear on land at 49-53 Victoria Road. This was implemented and is the building now known as York House, 49-51 Victoria Road. In March 2014 planning permission, 14/00029/COUPP, was granted for the change of use of this building from office use (Class B1a) to residential use (Class C3) to comprise 21 one bed and 2 two bed flats with associated car and cycle parking and refuse facilities. This permission has been implemented. This development would have been permitted development subject to a prior approval process but required permission as a result of the Habitats Regulations 2010 in relation to the impact on the Thames Basin Heaths Special Protection Area. This building and its car parking spaces are also owned by the applicant.

In January 2015 planning permission 14/00651/FULPP, was granted for the erection of third-floor extension and three-storey rear extension; and conversion of existing and new upper floors into 10 x 2 bedroom flats, with retention of 266m² of B1(a) office floorspace at ground floor at 61-65 Victoria Road. This permission is extant but has not been implemented at time of writing.

As originally submitted the proposal was for 11 apartments (1 studio, 5 one bed flats and 5 two bedroom flats). However concerns about internal space standards resulted in the applicant amending the internal layout to address this concern. The current proposal therefore seeks permission to erect a part single part three storey building with a pitched roof containing of 10 apartments (4 one bed flats and 6 two bedroom flats) with associated car and cycle parking, landscaping, amenity space, bin storage taking vehicular access from Sarah Way. The building would have its front elevation facing Sarah Way. Separation distances of some 4.5 metres are retained between the building and the common boundaries with 39 Clockhouse Road and 7a Elmgrove Road to the west, some 2.5 metres to the common boundary with 13-27 Pipers Patch, some 5 metres to the common boundary with 35 Clockhouse Road to the north and between 7.5 and 9.5 metres from the parking area that serves York House. Windows in the side elevations above ground levels are shown to be high level and clear glazed. The building would have pitched roofs with flat central areas. The general height of the main part of the development is approximately 11.8 metres with gabled details to the front and rear elevations. The single storey element is on the western side of the building and has a maximum ridge height of some 4.5 metres. The proposed materials include a mixture of brickwork panels, render, metal cladding, sliding timber screens, UPVc windows and clay roof tiles. The existing vehicular entrance points from Sarah Way will be retained leading to a parking area of 11 spaces at the rear. An enclosed communal bin store is proposed to the west of the building with secure cycle storage (8 hoops to accommodate 16 cycles) proposed to the east of the building. Communal amenity space is proposed to the rear of the building with "Juliet" balconies proposed to the front and rear of the majority of the first and second floor flats.

The application is supported by a design and access statement, a transport statement, a flood risk assessment including a conceptual drainage strategy, a tree report comprising a tree survey and constraint advice and an ecological appraisal.

Consultee Responses

Transportation Strategy Officer raises no objection to the proposal

Planning Policy raises no objection to the proposal.

Community - Contracts Manager	raises no objection to the proposal.
Parks Development Officer	raises no objection to the proposal subject to a financial contribution towards open space.
Ecologist Officer	raises no objection to the proposal subject to the recommendations in the ecological report being implemented in full.
Hampshire Fire & Rescue Service	advises that the development should be undertaken in accordance with Approved Document B5 of the Building Regulations and section 12 of the Hampshire Act 1983. Comments are also made in relation to access for high reach appliances, water supplies, sprinklers, fire fighting and the environment and timber framed buildings.
Environmental Health	raises no objection subject to an hours of construction condition.
Surface Water Drainage Consultations	has no comment to make on the application.
TAG	raises no objection to the proposal.
Arboricultural Officer	no adverse comments received
Thames Water	raises no objection to the proposal on grounds of sewerage infrastructure capacity. It recommends the imposition of a condition to secure a piling method statement to safeguard the sewerage infrastructure. It confirms that it is the developer's responsibility to make proper provision for drainage to ground, water courses or a suitable sewer. In respect of surface water it is recommended that the applicant should ensure that storm flows are attenuated or regulated into the receiving public network through on or off site storage. When it is proposed to connect to a combined public sewer, the site drainage should be separate and combined at the final manhole nearest the boundary. Connections are not permitted for the removal of groundwater. Where the developer proposes to discharge to a public sewer, prior approval from Thames Water Developer Services will be required.

Neighbours notified

In addition to posting a site notice and press advertisement, 78 individual letters of notification were sent to addresses in Clockhouse Road Elm Grove Road and Victoria Road,

Neighbour comments

Representations have been received from 43 Victoria Road and 16, 17 and 20 York House 49 Victoria Road raising the following concerns:

- it would be better if the proposal followed the type of development in neighbouring Clockhouse Road rather than yet more flats;
- potential for loss of privacy as a result of increased overlooking;
- loss of visitor parking to York House;
- the area has lots of double and single lines and the increase in flats with a limited number of parking spaces will cause issues;
- impact from construction vehicles on the safe operation of access and parking into the site and that associated with the existing flats at York House;
- potential impact on adjoining residents from the amount of dust and dirt associated with the construction process; and
- potential damage to residents vehicles by construction vehicles.

A representation has been received from a resident of Elm Grove Road who advises that whilst the proposal is generally a positive development plan, he enquires how unauthorised parking will be handled, given existing parking restrictions in the area. He comments that he has never seen any vehicle issued with a PCN on Sarah Way or the business parking areas and notes that traffic wardens only ever issue parking tickets along the vicinity of Elm Grove Road.

Policy and determining issues

The application site is located within the built up area of Farnborough to the north of Farnborough town centre. As such Policies SS1 (The Spatial Strategy), CP1 (Sustainable Development Principles), CP2 (Design and Heritage), CP3 (Renewable Energy and Sustainable Construction), CP4 (Surface Water Flooding), CP5 (Meeting Housing Needs and Housing Mix), CP8 (Supporting Economic Development), CP10 (Infrastructure Provision), CP12 (Open Space, Sport and Recreation), CP13 (Thames Basin Heaths Special Protection Area), CP15 (Biodiversity), CP16 (Reducing and Managing Travel Demand) and CP17 (Investing in Transport) of the Rushmoor Core Strategy and "saved" Local Plan Policies ENV16 (Development Characteristics), ENV19 (New Landscaping Requirements), ENV41-44 (Flood Risk), ENV48, ENV49, ENV50 and ENV51 (Environmental Pollution and Noise), H14 (amenity space), TR10 (Contributions for Local Transport Infrastructure), and OR4/OR4.1 (Open Space) are relevant to the consideration of this proposal. The Council's adopted planning documents (SPD) on 'Housing Density and Design' (May 2006), 'Planning Contributions - Transport' 2008; and 'Car and Cycle Parking Standards', 2012, the Rushmoor Thames Basin Heaths Special Protection Area Interim Avoidance and Mitigation Strategy as updated July 2014 and the advice contained in the National Planning Policy Framework/Planning Practice Guidance are also relevant.

The main determining issues are the principle of development, the effect on the character of the area, the impact on neighbours, the living environment created, flood risk and drainage issues, highway considerations, open space provision, nature conservation and renewable energy and construction.

Commentary

The principle of development

The site is located within the defined built up area. Planning Policy has confirmed that there are no site specific policies related to this area. Subsequently, the principle of introducing residential development in this location is acceptable. Having regard to this there is no objection in principle to residential redevelopment of the site subject to consideration of the following matters.

The effect on the character of the area

As existing the site is surrounded by existing development, with purpose built housing to the north, east and west with offices/converted offices to the south. The site is seen in the context of existing development with limited views seen from Elmgrove Road and Clockhouse Road. As such the site makes little visual contribution to the surrounding street scenes. Due to the height of development on Victoria Road no views are seen of the site from Victoria Road. As development of surrounding land has taken place on a piecemeal basis the visual character of the area is eclectic with buildings of varying heights, designs and use of materials. The application site is different to the typical pattern of development in the area in that does not comprise conventional frontage development.

It is recognised that the proposed development will have a different impact on the character of the area in terms of both built form and land use particularly by virtue of the introduction of a three storey element, accommodation within the roofspace and the overall height. However given its location surrounded by existing development it is not considered to have a detrimental impact on the character of the area. It reflects the objectives set out in the NPPF to make best use of brownfield land in sustainable locations and brings vacant land back into beneficial use. The increase in height and amount of development is different but is not considered to be unacceptable in this location. Having regard to the above no objection is raised to the proposal in visual amenity terms.

The impact on neighbours

With regard to the impact on 35 Clockhouse Road, this property is to the north of the application site and comprises a bungalow and its garden. There is established Leyland Cypress evergreen screening along the common boundary with the application site which is in excess of 6.5 metres in height. It is acknowledged that the upper floors of the proposed building will be visible from this property and there will be a degree of overlooking and overshadowing to the lower part of the rear garden. However given a minimum separation distance of just under 25 metres being retained, the boundary screening within the control of 35 Clockhouse Road and the general pattern of existing building relationships in the area, no material overbearing or overshadowing impacts nor a material loss of privacy are considered to result.

39 Clockhouse Road is a detached bungalow to the west of the application site. The building has been designed such that the closest part of the building to this property is single storey with this element having a height of some 4.5 metres with a separation distance of some 4.5 metres to the site boundary. The building then increases in height to 3 storey retaining a separation of distance of some 9 metres. This means that given the orientation of development there is potential for some overshadowing impact in the first half of the morning. However given the single storey design of the building closest to this property and the separation distances retained, this impact is not considered to be materially harmful such that permission should be refused on this basis. Furthermore it is not considered that the proposal would result in unacceptable overbearing impact. Given the siting of the building the windows in the rear elevation of the building would result in indirect overlooking of the front of 39 Clockhouse Road. This is not considered to result in a material loss of privacy.

High level windows are proposed at second floor level in the side (west) elevation. They have the potential to directly overlook 39 Clockhouse Road. These windows are shown to serve a bedroom and kitchen/living room with a minimum cill height of 1.7 metres from floor level. It is therefore considered that an appropriate level of occupational privacy would be retained and no objection is raised to the proposal in this regard. The proposed refuse/recycling enclosure is located between the proposed building and the boundary with 39 Clockhouse Road. This is would be 2 metres high and of timber construction. Having regard to existing boundary fencing and the height of the enclosure these factors are considered to be sufficient to screen the storage area from view and as such no objection is raised to the proposal in this regard.

13-27 Pipers Patch lies to the east of the proposed development. This comprises a three storey block of flats. The primary windows in this building face to the front and rear with secondary windows in the side elevation at ground, first and second floor levels. Communal amenity space lies to the north of the building with individual front garden areas to the south. This site benefits from established landscaping. Four high level windows are proposed in first and second floor side elevations (two per floor) to serve bedrooms at second floor and secondary bedroom windows at first floor which have the potential to directly overlook these adjoining residents. Information has been submitted in respect of the second floor windows which demonstrate that with a minimum cill height of 1.7 metres from floor level, an appropriate level of occupational privacy would be retained. In the absence of information relating to the cill height of the first floor windows it is considered appropriate to impose a condition seeking the use of obscure glazing in these windows. Subject to this no material loss of privacy is considered to result from this proposal. Given the location of 13-27 Pipers Patch to the east of the site, there is the potential for a degree of overshadowing in the latter part of the day. However given the separation distance retained, the secondary nature of the windows in the existing flats (serving bedrooms and living rooms), the location of Lawson Cypress and Yew trees adjacent to the common boundary, the semi-public nature of front gardens and the siting of the proposed building, no material overshadowing impacts are considered to result. Furthermore it is not considered that the proposal would result in unacceptable overbearing impacts.

With regard to the occupiers of York House, it is noted that, in terms of direct overlooking, a separation distance in excess of 40 metres will be retained between the front elevation of the proposed development and the rear elevation of York House. The proposed separation distance is considered to be sufficient to retain appropriate levels of privacy for these occupiers and as such no material loss of privacy to these occupiers is considered to result. Given the orientation of the development and the separation distances proposed, no material overshadowing or overbearing impacts are considered to result from the proposal. The proposed car parking area for the development is proposed adjacent to the parking spaces that serves York House. This relationship is considered to be acceptable.

The living environment created

In space terms the proposed dwellings would provide an acceptable living environment for its future occupants. The development benefits from communal amenity space to the rear with the majority of the flats having juliet balconies. Having regard to the proximity of the Queen Elizabeth Park and the amenity space provided for flat residents at Pipers Patch to the east, it is considered that an acceptable level of usable amenity space commensurate with the type of development proposed would be provided. Communal refuse/recycling bin and cycle storage would be provided which may be secured by way of condition. Subject to the imposition of this condition, it is considered that the proposal would create a satisfactory living environment for future residents and is acceptable.

Flood risk and drainage issues

Policy CP4 relates to surface water flooding and seeks details of sustainable drainage systems that will be incorporated into the development. It is noted that there are no permeable areas within the existing site. The introduction of garden/landscaped areas and the use of permeable hard surfaces will be a positive benefit to surface water drainage. Notwithstanding this the application is supported by an outline SUDS drainage design. This information has been considered in detail by Hampshire County Council, in its role as Lead Local Flood Authority (LLFA) and Thames Water. The LLFA and Thames Water raise no objection to the submitted information. Furthermore Thames Water raise no objection to the proposal in terms of sewerage infrastructure. Whilst feasible SUDS techniques for the site have been provided within the Flood Risk Assessment, no detailed SUDS strategy has been submitted. These details may be secured by way of condition. Subject to the imposition of a condition as set out above no objection is raised to the proposal in terms of policy CP4.

Highway considerations

The proposal is for a development of 10 apartments which comprise of 4 x one bedroom flats and 6 x two bedroom flats on a site to the rear of York House. The proposed site layout shows 11 car parking spaces to serve the development. The Council's Transportation Strategy Officer has been consulted on this application. In view of the relatively accessible location of the development in proximity to the town centre and to the rail station he is satisfied that this level of parking provision is acceptable. Further to this while our full parking standard would require 3 visitors parking spaces it is his view that it can be reasonably expected that visitors to this site could park in town centre car parks. The site layout shows the 11 parking spaces the space marked N10 is not 6m in length which would normally be needed to be accessible in the orientation shown however as it is adjacent a hatched area in front of the cycle store entrance he is satisfied that this hatched area does give the manoeuvring space that is required. The location of the refuse store appears to be accessible from the point of collection while the swept path tracking diagram uses a slightly different site layout he is satisfied that this demonstrates how a refuse freighter will turn at the end of Sarah Way to access the store from within 25m. Cycle parking provision is considered to be acceptable.

The Transportation Strategy Officer is also satisfied that as there is no increase in multi modal trips arising from the development when compared to the former use of this site, there is no requirement for a financial contribution in respect of the Council's SPD on Planning Contributions - Transport. Subject to the imposition of conditions as set out above, no objection is raised to the proposal on highway grounds.

Open space provision

The Local Plan seeks to ensure that adequate open space provision is made to cater for future residents in connection with new residential developments. Policies OR4 and OR4.1 allow provision to be made on the site, or in appropriate circumstances a contribution to be made towards upgrading facilities nearby. The policy does not set a threshold of a particular number of dwellings or size of site above which the provision is required.

The site is not big enough to accommodate anything other than the development proposed and any associated garden/private amenity space. This is a circumstance where a contribution towards off-site provision, in this case for the improvement of the car park, footpaths and playground at Queen Elizabeth Park and sport pitches at Farnborough Gate

sports complex by way of a planning obligation may be appropriate. The applicant is in the process of completing the necessary agreement and subject to this no objection is raised to the proposal within the terms of Policy OR4.

Nature conservation

The Rushmoor Thames Basin Heaths Special Protection Area Interim Avoidance and Mitigation Strategy is now in place. This comprises two elements - a Suitable Alternative Natural Greenspace (SANG) at Hawley Meadows/Blackwater Park to divert additional recreational pressure away from the Thames Basin Heaths Special Protection Area (TBHSPA) and a range of Strategic Access Management and Monitoring Measures to avoid displacing visitors from one part of the TBHSPA to another and to minimize the impact of visitors on the TBHSPA. The proposal meets the criteria against which requests to allocate capacity at Hawley Meadows/Blackwater Park SANG will be considered. In accordance with the strategy the applicant has agreed to make the requisite financial contribution. The applicant is in the process of completing the necessary agreement and subject to this no objection is raised to the proposal in terms of its impact on the TBHSPA having regard to the above strategy and development plan policy.

Renewable energy and construction.

Following the Royal Assent of the Deregulation Bill 2015 (26 March 2015) the government's current policy position is that planning permissions should not be granted requiring or subject to conditions requiring, compliance with any technical housing standards for example the Code for Sustainable Homes, other than for those areas where authorities have existing policies. In Rushmoor's case this means that we can require energy performance in accordance with Code Level 4 as set out in policy CP3 of the Rushmoor Core Strategy. Such measures may be secured by way of condition and on this basis no objection is raised to the proposal in terms of policy CP3.

Extension of Time

Due to the discussions concerning the internal layout of the development, there has been a delay in confirming the contributions relevant to this proposal to the applicant. Consequently a request has been received from the applicant to extend the time for the determination of this application to 20 April 2016 to enable the undertaking to be completed. This has been agreed.

Conclusion

In conclusion the proposal is acceptable in principle. It would have an acceptable impact on the character of the area, it will create a satisfactory living environment for future occupiers, have an acceptable impact on adjoining non-residential and residential occupiers and meet the functional requirements of the development. The proposal is acceptable in highway terms, it makes satisfactory provision for public open space and an appropriate contribution towards SPA mitigation measures and secures appropriate energy efficiency measures. It complies with development plan policies, the Council's adopted Rushmoor Thames Basin Heaths Special Protection Area Interim Avoidance and Mitigation Strategy and the National Planning Policy Framework/Planning Practice Guidance and is recommended for approval.

Full Recommendation

It is recommended that subject to the completion of a satisfactory Agreement under s106 of

the Town and Country Planning Act 1990 by 18 April 2016 to secure financial contributions towards SPA mitigation and open space the Head of Planning in consultation with the Chairman be authorised to **GRANT** planning permission subject to the following conditions and informatives:-

However, in the event that a satisfactory s106 Agreement is not received by 18 April 2016 the Head of Planning, in consultation with the Chairman, be authorised to refuse planning permission on the grounds that the proposal fails to make provision for open space contrary to the provisions of policy CP12 of the Rushmoor Core Strategy and "saved" policy OR4 of the Rushmoor Local Plan Review 1996-2011 and to provide mitigation for the impact of the development on the Thames Basin Heaths Special Protection Area in accordance with the Council's Thames Basin Heaths Special Protection Area Interim Avoidance and Mitigation Strategy contrary to Policy CP13 of the Rushmoor Core Strategy.

- 1 The development hereby permitted shall be begun before the expiration of one year from the date of this permission.

Reason - As required by Section 91 of the Town and Country Planning Act 1990 as amended by Section 51 of the Planning and Compulsory Purchase Act 2004, to reflect the objectives of the Council's Thames Basin Heaths Special Protection Area Avoidance and Mitigation Strategy as amended July 2014 and to accord with the resolution of Rushmoor's Cabinet on 17 June 2014 in respect of Planning Report no PLN1420.

- 2 Notwithstanding any details submitted with the application, no works shall start on site until a schedule and/or samples of the external materials to be used in the development have been submitted to, and approved in writing by, the Local Planning Authority. The Development shall be completed and retained in accordance with the details so approved.

Reason - To ensure satisfactory external appearance.*

- 3 No works shall start on site until a schedule and/or samples of surfacing materials, including those to access driveways/parking areas to be used in the development have been submitted to, and approved in writing by, the Local Planning Authority. The development shall be completed and retained in accordance with the details so approved

Reason - To ensure satisfactory external appearance and drainage arrangements.*

- 4 The development shall be completed and retained in accordance with the levels shown on the approved plans.

Reason - To ensure a satisfactory form of development in relation to neighbouring property.*

- 5 The building shall not be occupied until details of all screen and boundary walls, fences, hedges or other means of enclosure have been submitted to and approved in writing by the Local Planning Authority. The development shall be completed prior to first occupation and thereafter retained in accordance with the details so approved.

Reason - To safeguard the amenities of neighbouring property.*

- 6 Construction or demolition work of any sort within the area covered by the application shall only take place between the hours of 0800-1800 on Monday to Fridays and 0800-1300 on Saturdays. No work at all shall take place on Sundays and Bank or Statutory Holidays.

Reason - To protect the amenities of neighbouring residential properties and to prevent adverse impact on traffic and parking conditions in the vicinity.

- 7 No works shall start on site until a construction method statement has been submitted to and approved in writing by the Local Planning Authority, which shall include:

- i) a programme of construction work;
- ii) the provision of facilities for contractor parking;
- iii) the arrangements for deliveries associated with all construction works;
- iv) access and egress for plant and deliveries;
- v) protection of pedestrian routes and boundaries with adjoining land/buildings during construction;
- vii) location of temporary site buildings, site compounds, construction materials and plant storage areas;
- vii) controls over dust, noise and vibration during the construction period; and
- viii) provision for storage, collection and disposal of rubbish from the development during the construction period

Construction shall only take place in accordance with the approved method statement.

Reason - To protect the amenities of neighbouring, to prevent pollution and to prevent adverse impact on highway conditions in the vicinity.*

- 8 The landscaping scheme as shown on drawing number L800 rev P3 shall be implemented in full prior to the first occupation of any part of the development or the first available planting season whichever is the sooner. Any tree/shrub removed, dying or becoming seriously diseased within five years of planting shall be replaced by trees/shrubs of similar size and species to those originally required to be planted.

Reason - To ensure the development makes an adequate contribution to visual amenity and in the interests of biodiversity

- 9 No dwelling shall be occupied until the off-street parking facilities shown on the approved plans relevant to that dwelling have been completed and made ready for use by the occupiers. The parking facilities shall be thereafter retained solely for parking purposes (to be used by the occupiers of, and visitors to, the development) and, in the interests of clarity, not used for the storage of caravans, boats or trailers .
*

Reason - To ensure the provision and availability of adequate off-street parking

- 10 No part of the development hereby approved shall be used or occupied until the means of vehicular access onto Sarah Way has been made available for use.

Reason - To ensure adequate means of access is available to the development.

- 11 In the event that unforeseen ground conditions or materials which suggest potential or actual contamination are revealed at any time during implementation of the approved development it must be reported, in writing, immediately to the Local Planning

Authority. A competent person must undertake a risk assessment and assess the level and extent of the problem and, where necessary, prepare a report identifying remedial action which shall be submitted to and approved in writing by the Local Planning Authority before the measures are implemented. Following completion of measures identified in the approved remediation scheme a verification report must be prepared and is subject to approval in writing by the Local Planning Authority.

Reason - To ensure that the site is safe for the development permitted and in the interests of amenity and pollution prevention

- 12 Prior to the commencement of development, and notwithstanding any details submitted with the application, a detailed Sustainable Drainage Systems (SUDS) strategy shall be submitted to and approved in writing by the Local Planning Authority. Such details as may be approved shall be implemented in full prior to the first occupation of that part of the development to which they relate and retained in perpetuity.

Reason - To reflect the objectives of Policy CP4 of the Rushmoor Core Strategy

- 13 Prior to the commencement of development, and notwithstanding any details submitted with the application, details of measures to achieve the energy performance standards in accordance with Code Level 4 for Sustainable Homes or equivalent shall be submitted to and approved in writing by the Local Planning Authority. Such details as may be approved shall be implemented in full prior to the first occupation of the plot to which they relate and retained in perpetuity.

Reason - To reflect the objectives of Policy CP3 of the Rushmoor Core Strategy

- 14 Notwithstanding the provisions of condition 9 above, the parking spaces shown on the approved plans shall be provided in accordance with a plan which shows car parking spaces allocated to individual properties which shall be submitted to the Local Planning Authority for approval prior to first occupation of the development and once approved shall be retained as such.

Reason - To safeguard residential amenity and ensure the provision and availability of adequate off-street parking.

- 15 No works shall start on site until details of communal aerial/satellite facilities for the development have been submitted to and approved in writing by the Local Planning Authority. The approved system shall then be installed and made operational before the relevant dwellings are occupied. *

Reason - In the interests of the visual amenity of the area.

- 16 The refuse and cycle storage areas as shown on the approved plans shall be provided prior to the occupation of any part of the development and thereafter retained for their designated purpose.

Reason - To promote sustainable transport choices and to meet the functional requirements of the development.

- 17 The secondary bedroom windows in the side elevation serving flats 6 and 7 shall be completed in obscure glazing and thereafter retained.

Reason – To safeguard an appropriate level of privacy to adjoining residents at Pipers Patch

- 18 The permission hereby granted shall be carried out in accordance with the following approved drawings - 4401_A_L522_P4, L523_P3, L530_P6, L531_P5, L100 rev P5, L800 rev P3 and A368 rev A

Reason - To ensure the development is implemented in accordance with the permission granted

Informatives

- 1 **INFORMATIVE –** The Local Planning Authority’s commitment to working with the applicants in a positive and proactive way is demonstrated by its offer of pre-application discussion to all, free of charge, and assistance in the validation and determination of applications through the provision of clear guidance regarding necessary supporting information or amendments both before and after submission, in line with the National Planning Policy Framework.
- 2 **INFORMATIVE - REASONS FOR APPROVAL -** The Council has granted permission because the proposal would have an acceptable impact on the character of the area. It has been satisfactorily demonstrated that the proposal that it will create a satisfactory living environment for future occupiers, have an acceptable impact on adjoining non-residential occupiers and meet the functional requirements of the development. The proposal is acceptable in highway terms, it makes satisfactory provision for public open space and an appropriate contribution towards SPA mitigation measures. As such it complies with development plan policies, the Council's adopted SPDs on Car and Cycle Parking Standards and Planning Contributions - Transport and The Rushmoor Thames Basin Heaths Special Protection Area Interim Avoidance and Mitigation Strategy and the National Planning Policy Framework/Planning Practice Guidance. It is therefore considered that subject to compliance with the attached conditions, and taking into account all other material planning considerations, including the provisions of the development plan, the proposal would be acceptable. This also includes a consideration of whether the decision to grant permission is compatible with the Human Rights Act 1998.
- 3 **INFORMATIVE -** Your attention is specifically drawn to the conditions marked *. These conditions require the submission of details, information, drawings etc. to the Local Planning Authority **BEFORE WORKS START ON SITE** or, require works to be carried out **BEFORE COMMENCEMENT OF USE OR FIRST OCCUPATION OF ANY BUILDING**. Development started, carried out or occupied without first meeting the requirements of these conditions is effectively development carried out **WITHOUT PLANNING PERMISSION**. The Council will consider the expediency of taking enforcement action against any such development and may refer to any such breach of planning control when responding to local searches. Submissions seeking to discharge conditions or requests for confirmation that conditions have been complied with must be accompanied by the appropriate fee.
- 4 **INFORMATIVE -** This permission is subject to a planning obligation under Section 106 of the Town and Country Planning Act 1990 (as amended).

- 5 INFORMATIVE - The applicant is recommended to achieve maximum energy efficiency and reduction of Carbon Dioxide emissions by: a) ensuring the design and materials to be used in the construction of the building are consistent with these aims; and b) using renewable energy sources for the production of electricity and heat using efficient and technologically advanced equipment for the production of electricity and heat.
- 6 INFORMATIVE - The applicant is advised to follow good practice in the removal of the existing hardstanding on site including the re-use of all material arising from demolition as part of the redevelopment wherever practicable. Please contact Les Murrell, Strategy Co-ordinator (Sustainability) at Rushmoor Borough Council on 01252 398538 for further information.
- 7 INFORMATIVE - The applicant is advised to contact the Recycling and Waste Management section at Rushmoor Borough Council on 01252 398164 with regard to providing bins for refuse and recycling. The bins should be: 1) provided prior to the occupation of the properties; 2) compatible with the Council's collection vehicles, colour scheme and specifications 3) appropriate for the number of occupants they serve; 4) fit into the development's bin storage facilities.
- 8 INFORMATIVE - The planning permission hereby granted does not authorise the applicant, or his agents, to construct a new/altered access to, or other work within, the public highway. A separate consent for works within the highway must first be obtained from the highway authority who may be contacted at the following address:- Hampshire County Council Highways Sub Unit, M3 Motorway Compound, Hook, Hampshire, RG27 9AA.
- 9 INFORMATIVE - Measures should be taken to prevent mud from vehicles leaving the site during construction works being deposited on the public highway throughout the construction period.
- 10 INFORMATIVE - No materials produced as a result of site preparation, clearance, or development should be burnt on site. Please contact the Head of Environmental Health for advice
- 11 INFORMATIVE - The applicant is advised that there may be a need to comply with the requirements of the Party Wall (etc.) Act 1996 before starting works on site. The Party Wall (etc.) Act is not enforced or administered by the Council but further information can be obtained from the Chief Building Control Officer.
- 12 INFORMATIVE - It is a legal requirement to notify Thames Water of any proposed connection to a public sewer. In many parts of its sewerage area, Thames Water provides separate public sewers for foul water and surface water. Within these areas a dwelling should have separate connections: a) to the public foul sewer to carry waste from toilets, sinks and washing machines, etc, and b) to public surface water sewer for rainwater from roofs and surface drains. Mis-connections can have serious effects: i) If a foul sewage outlet is connected to a public surface water sewer this may result in pollution of a watercourse. ii) If a surface water outlet is connected to a public foul sewer, when a separate surface water system or soakaway exists, this may cause overloading of the public foul sewer at times of heavy rain. This can lead to sewer flooding of properties within the locality. In both instances it is an offence to

make the wrong connection. Thames Water can help identify the location of the nearest appropriate public sewer and can be contacted on 0845 850 2777.

- 13 INFORMATIVE - The applicant is advised that during the demolition and construction phases of the development measures should be employed to contain and minimise dust emissions, to prevent their escape from the development site onto adjoining properties. For further information, please contact the Head of Environmental Health.
- 14 INFORMATIVE - The applicant is requested to bring the conditions attached to this permission to the attention of all contractors working or delivering to the site, in particular any relating to the permitted hours of construction and demolition; and where practicable to have these conditions on display at the site entrance(s) for the duration of the works.
- 15 INFORMATIVE - The applicant's attention is drawn to water efficiency and the new national technical standard i.e. all new homes have to meet the mandatory national standard set out in the Building Regulations (of 125 litres/person/day).

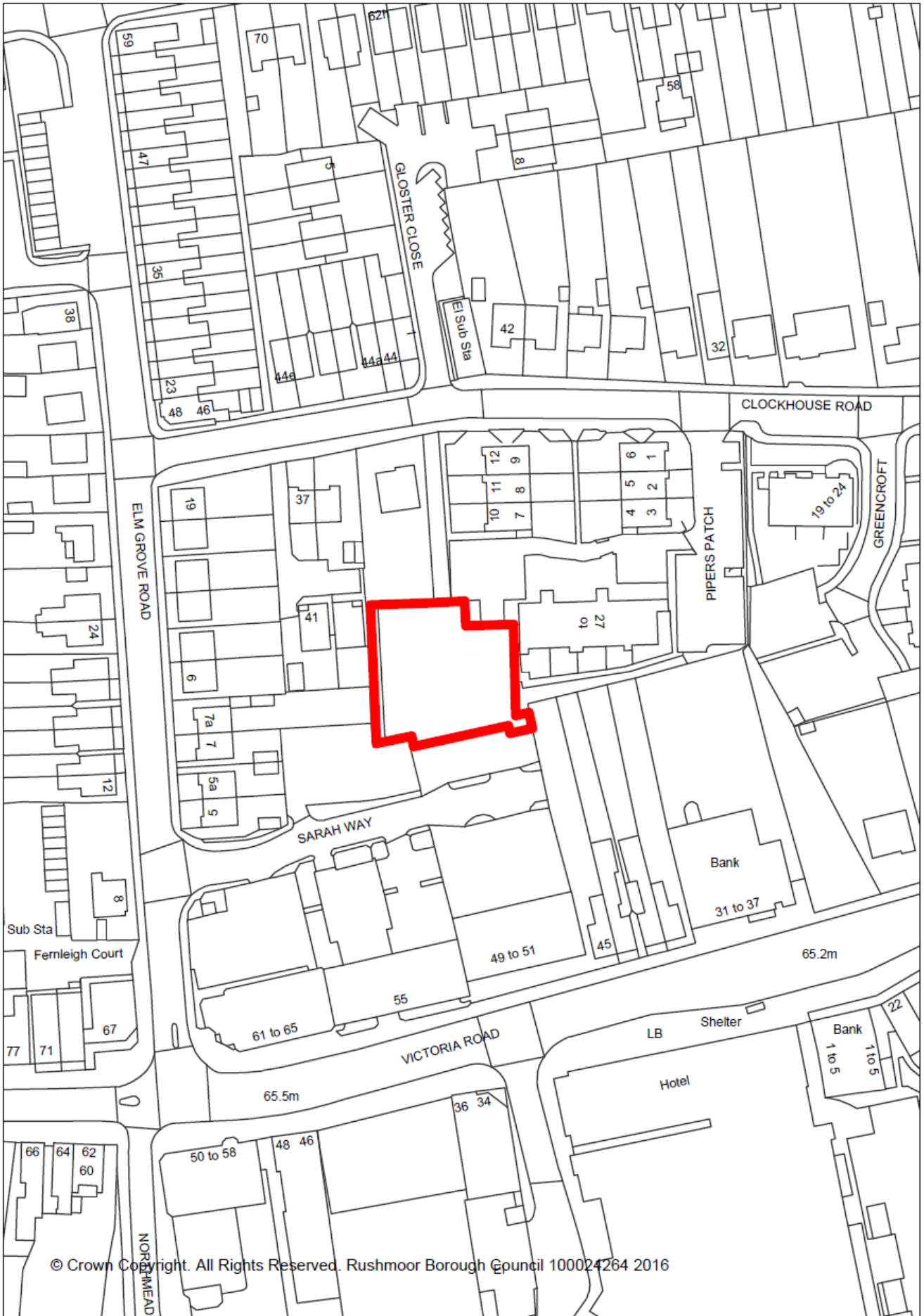

© Crown Copyright. All Rights Reserved. Rushmoor Borough Council 100024264 2016

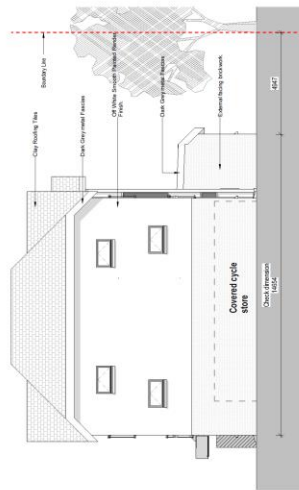
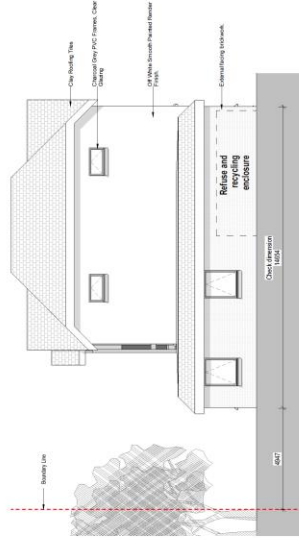
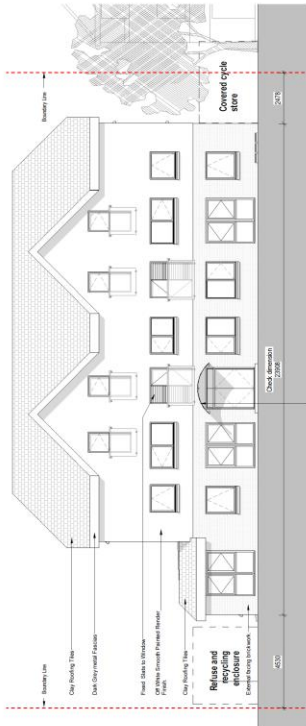
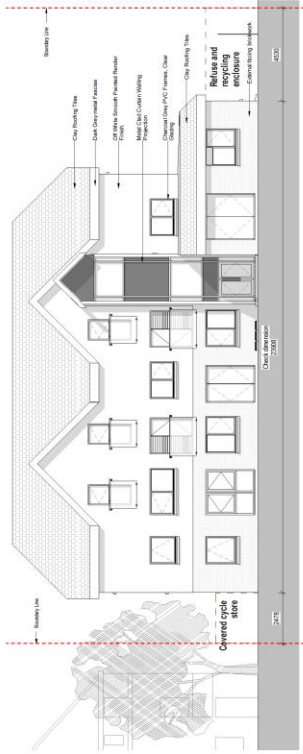

No. 1 | Project No. | 4401_A_L511_P5
 Date | 05/01/2015 | 10:00 AM
 By | David | 4401_A_L511_P5
 Check | David | 4401_A_L511_P5
 Scale | 1:200 @A1 | 05/01/2015 | 10:00 AM
 Project Name | 4401 | 4401_A_L511_P5
 Discipline | PLANNING
 Project No. | 4401 | 4401_A_L511_P5
 Project Name | 4401 | 4401_A_L511_P5
 Project No. | 4401 | 4401_A_L511_P5
 Project Name | 4401 | 4401_A_L511_P5

househamhenderson
 12 Charlotte Street, Bristol, Bristol, UK
 01274 800000
 david@househamhenderson.com

Client
Gammaker Asset Management
 Sarah Way Development

Project
PROPOSED RESIDENTIAL DEVELOPMENT ELEVATIONS



Scheme K6 Legend



Units	Area	Floor SF	Blocks	Person
U1	Ground Floor	565.00 SF	1 Block	2 Person
Floor 2	44.82 SF	480.00 SF	1 Block	2 Person
Floor 3	44.82 SF	480.00 SF	1 Block	2 Person
Floor 4	44.82 SF	480.00 SF	1 Block	2 Person
U1	First Floor	565.00 SF	1 Block	2 Person
Floor 5	44.82 SF	480.00 SF	1 Block	2 Person
Floor 6	44.82 SF	480.00 SF	1 Block	2 Person
Floor 7	44.82 SF	480.00 SF	1 Block	2 Person
U2	Second Floor	565.00 SF	1 Block	2 Person
Floor 8	44.82 SF	480.00 SF	1 Block	2 Person
Floor 9	44.82 SF	480.00 SF	1 Block	2 Person
Floor 10	44.82 SF	480.00 SF	1 Block	2 Person
U3	Third Floor	565.00 SF	1 Block	2 Person
Floor 11	44.82 SF	480.00 SF	1 Block	2 Person
Floor 12	44.82 SF	480.00 SF	1 Block	2 Person
Floor 13	44.82 SF	480.00 SF	1 Block	2 Person
U4	Fourth Floor	565.00 SF	1 Block	2 Person
Floor 14	44.82 SF	480.00 SF	1 Block	2 Person
Floor 15	44.82 SF	480.00 SF	1 Block	2 Person
Floor 16	44.82 SF	480.00 SF	1 Block	2 Person
U5	Fifth Floor	565.00 SF	1 Block	2 Person
Floor 17	44.82 SF	480.00 SF	1 Block	2 Person
Floor 18	44.82 SF	480.00 SF	1 Block	2 Person
Floor 19	44.82 SF	480.00 SF	1 Block	2 Person
Floor 20	44.82 SF	480.00 SF	1 Block	2 Person
U6	Sixth Floor	565.00 SF	1 Block	2 Person
Floor 21	44.82 SF	480.00 SF	1 Block	2 Person
Floor 22	44.82 SF	480.00 SF	1 Block	2 Person
Floor 23	44.82 SF	480.00 SF	1 Block	2 Person
Floor 24	44.82 SF	480.00 SF	1 Block	2 Person
Floor 25	44.82 SF	480.00 SF	1 Block	2 Person
Floor 26	44.82 SF	480.00 SF	1 Block	2 Person
Floor 27	44.82 SF	480.00 SF	1 Block	2 Person
Floor 28	44.82 SF	480.00 SF	1 Block	2 Person
Floor 29	44.82 SF	480.00 SF	1 Block	2 Person
Floor 30	44.82 SF	480.00 SF	1 Block	2 Person
Floor 31	44.82 SF	480.00 SF	1 Block	2 Person
Floor 32	44.82 SF	480.00 SF	1 Block	2 Person
Floor 33	44.82 SF	480.00 SF	1 Block	2 Person
Floor 34	44.82 SF	480.00 SF	1 Block	2 Person
Floor 35	44.82 SF	480.00 SF	1 Block	2 Person
Floor 36	44.82 SF	480.00 SF	1 Block	2 Person
Floor 37	44.82 SF	480.00 SF	1 Block	2 Person
Floor 38	44.82 SF	480.00 SF	1 Block	2 Person
Floor 39	44.82 SF	480.00 SF	1 Block	2 Person
Floor 40	44.82 SF	480.00 SF	1 Block	2 Person
Floor 41	44.82 SF	480.00 SF	1 Block	2 Person
Floor 42	44.82 SF	480.00 SF	1 Block	2 Person
Floor 43	44.82 SF	480.00 SF	1 Block	2 Person
Floor 44	44.82 SF	480.00 SF	1 Block	2 Person
Floor 45	44.82 SF	480.00 SF	1 Block	2 Person
Floor 46	44.82 SF	480.00 SF	1 Block	2 Person
Floor 47	44.82 SF	480.00 SF	1 Block	2 Person
Floor 48	44.82 SF	480.00 SF	1 Block	2 Person
Floor 49	44.82 SF	480.00 SF	1 Block	2 Person
Floor 50	44.82 SF	480.00 SF	1 Block	2 Person
Floor 51	44.82 SF	480.00 SF	1 Block	2 Person
Floor 52	44.82 SF	480.00 SF	1 Block	2 Person
Floor 53	44.82 SF	480.00 SF	1 Block	2 Person
Floor 54	44.82 SF	480.00 SF	1 Block	2 Person
Floor 55	44.82 SF	480.00 SF	1 Block	2 Person
Floor 56	44.82 SF	480.00 SF	1 Block	2 Person
Floor 57	44.82 SF	480.00 SF	1 Block	2 Person
Floor 58	44.82 SF	480.00 SF	1 Block	2 Person
Floor 59	44.82 SF	480.00 SF	1 Block	2 Person
Floor 60	44.82 SF	480.00 SF	1 Block	2 Person
Floor 61	44.82 SF	480.00 SF	1 Block	2 Person
Floor 62	44.82 SF	480.00 SF	1 Block	2 Person
Floor 63	44.82 SF	480.00 SF	1 Block	2 Person
Floor 64	44.82 SF	480.00 SF	1 Block	2 Person
Floor 65	44.82 SF	480.00 SF	1 Block	2 Person
Floor 66	44.82 SF	480.00 SF	1 Block	2 Person
Floor 67	44.82 SF	480.00 SF	1 Block	2 Person
Floor 68	44.82 SF	480.00 SF	1 Block	2 Person
Floor 69	44.82 SF	480.00 SF	1 Block	2 Person
Floor 70	44.82 SF	480.00 SF	1 Block	2 Person
Floor 71	44.82 SF	480.00 SF	1 Block	2 Person
Floor 72	44.82 SF	480.00 SF	1 Block	2 Person
Floor 73	44.82 SF	480.00 SF	1 Block	2 Person
Floor 74	44.82 SF	480.00 SF	1 Block	2 Person
Floor 75	44.82 SF	480.00 SF	1 Block	2 Person
Floor 76	44.82 SF	480.00 SF	1 Block	2 Person
Floor 77	44.82 SF	480.00 SF	1 Block	2 Person
Floor 78	44.82 SF	480.00 SF	1 Block	2 Person
Floor 79	44.82 SF	480.00 SF	1 Block	2 Person
Floor 80	44.82 SF	480.00 SF	1 Block	2 Person
Floor 81	44.82 SF	480.00 SF	1 Block	2 Person
Floor 82	44.82 SF	480.00 SF	1 Block	2 Person
Floor 83	44.82 SF	480.00 SF	1 Block	2 Person
Floor 84	44.82 SF	480.00 SF	1 Block	2 Person
Floor 85	44.82 SF	480.00 SF	1 Block	2 Person
Floor 86	44.82 SF	480.00 SF	1 Block	2 Person
Floor 87	44.82 SF	480.00 SF	1 Block	2 Person
Floor 88	44.82 SF	480.00 SF	1 Block	2 Person
Floor 89	44.82 SF	480.00 SF	1 Block	2 Person
Floor 90	44.82 SF	480.00 SF	1 Block	2 Person
Floor 91	44.82 SF	480.00 SF	1 Block	2 Person
Floor 92	44.82 SF	480.00 SF	1 Block	2 Person
Floor 93	44.82 SF	480.00 SF	1 Block	2 Person
Floor 94	44.82 SF	480.00 SF	1 Block	2 Person
Floor 95	44.82 SF	480.00 SF	1 Block	2 Person
Floor 96	44.82 SF	480.00 SF	1 Block	2 Person
Floor 97	44.82 SF	480.00 SF	1 Block	2 Person
Floor 98	44.82 SF	480.00 SF	1 Block	2 Person
Floor 99	44.82 SF	480.00 SF	1 Block	2 Person
Floor 100	44.82 SF	480.00 SF	1 Block	2 Person

Scheme K6 Legend



Scheme K6 Legend

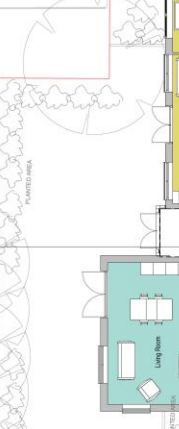

Refuse & Recycling area to be housed in 211000 bins for recycling, waste, and general refuse for 2000 units. Bin enclosure to be located adjacent to the refuse & recycling area.

COVERED CYCLE STORE

REFUSE & WASTE ENCLOSURE

Rev	Description	By	Check	Date
1	Initial Issue	JP	JM	2013
2	Revised	JP	JM	2013
3	Revised	JP	JM	2013

Location: 4401 A, L550, PB
 Client: Graham/Market Asset Management
 Project: Sarah Way Development
 Proposed Residential Development Plans
 Date: 05/01/2018
 Author: JP
 Checked: JM
 Project Number: 4401_A_L550_PB
 Drawing Number: 4401_A_L550_PB

Section D

The following applications are reported for INFORMATION purposes only. They relate to applications, prior approvals, notifications, and consultations that have already been determined by the Head of Planning and where necessary, in consultation with the Chairman, in accordance with the Council's adopted Scheme of Delegation.

If Members wish to have more details about the decision on any of the applications on this list please contact David Stevens (01252 398738) or John W Thorne (01252 398791) in advance of the Committee meeting.

Application No	15/00500/CONDPP	Ward: Aldershot Park
Applicant:	Stonewater Procurement Ltd	
Decision:	Conditions details approved	
Decision Date:	10 March 2016	
Proposal:	Submission of details to comply with conditions 2 (external materials), 4 (levels), 8 (landscaping), 13 (Code Level 4 Sustainable Homes) and 16 (Construction Method Statement) attached to planning permission 13/00963/FULPP dated 6 August 2014	
Address	Wavell Court Raglan Close Aldershot Hampshire GU12 4PG	

Application No	15/00564/CONDPP	Ward: Aldershot Park
Applicant:	Stonewater Procurement Ltd	
Decision:	Conditions details approved	
Decision Date:	10 March 2016	
Proposal:	Submission of details pursuant to conditions 2 (roof material), 3 (surfacing materials), 5 (boundary treatment), 6 (bin stores) and 12 (SUDS) attached to planning permission 13/00963/FULPP dated 6 August 2014	
Address	Wavell Court Raglan Close Aldershot Hampshire GU12 4PG	

Application No 15/00789/CONDPP Ward: Empress

Applicant: Knight Frank Investment Management

Decision: **Conditions details approved**

Decision Date: 11 March 2016

Proposal: Submission of details to comply with condition 21 (alternative pedestrian route) pursuant to planning permission 15/00176/FULPP dated 23 July 2015 for the erection of an extension to existing shopping centre to provide three retail units, alterations to the external appearance of existing tower feature, creation of rear service yard with access from Hawthorn Road and alterations to existing car park layout and landscaping

Address **Proposed Extension To Princes Mead Westmead Farnborough Hampshire**

Application No 15/00821/CONDPP Ward: St Mark's

Applicant: Mr R Raggett

Decision: **Conditions details approved**

Decision Date: 23 February 2016

Proposal: Submission of details pursuant to Conditions 4 (external materials), 5 (external surfacing materials), 6 (boundary treatments), 8 (landscaping), 12 (cycle store), 13 (Energy Performance Standards) & 14 (SUDS) attached to Planning Permission 15/00339/FULPP dated 24th August 2015

Address **Land Adjacent To 37 To 41 Cross Street And To The Rear Of 59 - 61 Southampton Street Farnborough Hampshire**

Application No 15/00894/NMAPP Ward: St Mark's

Applicant: Fleet Homes 2000 Ltd.

Decision: **Permission Granted**

Decision Date: 02 March 2016

Proposal: NON-MATERIAL AMENDMENT : Installation of gates on site access road and re-location of bin collection point as amendments to development approved by planning permission 13/00839/FULPP dated 16 June 2014

Address **Proposed Development Site At 11-17 And Land To The Rear Of 3 - 9 Somerset Road Farnborough Hampshire**

Application No 15/00904/CONDPP Ward: Wellington
Applicant: Mr Tanka Rana
Decision: **Conditions details approved**
Decision Date: 01 March 2016
Proposal: Submission of details to comply with condition 3 (existing and proposed colour finishes) attached to listed building consent 15/00438/LBC2PP dated 23 September 2015 in respect of internal and external alterations to the building
Address **35 Station Road Aldershot Hampshire GU11 1BA**

Application No 15/00920/FULPP Ward: West Heath
Applicant: First Wessex
Decision: **Permission Granted**
Decision Date: 07 March 2016
Proposal: Demolition of existing structures and erection of a pair of semi detached three bedroom houses and a terrace of 3 three bedroom houses with associated access, parking and landscaping.
Address **Garages Heathlands Close Farnborough Hampshire**

Application No 15/00966/REVPP Ward: St Mark's
Applicant: Millstone Homes
Decision: **Permission Granted**
Decision Date: 15 March 2016
Proposal: Removal of Condition No.5 (sustainable construction certification) imposed by planning permission 14/00796/FULPP granted on 16th January 2015
Address **93 Somerset Road Farnborough Hampshire GU14 6DR**

Application No 15/00973/REVPP Ward: Knellwood
Applicant: Dr M & S Hussain
Decision: **Permission Granted**
Decision Date: 11 March 2016
Proposal: MATERIAL MINOR AMENDMENT : Revisions to scheme approved by planning permission 15/00543/FULPP dated 18/09/2015 to allow amendments to design of dwellinghouse
Address **Land To The Rear Of 145 Alexandra Road Farnborough Hampshire**

Application No 15/00975/CONDPP Ward: Cherrywood
Applicant: Mr R Walls
Decision: **Conditions details approved**
Decision Date: 03 March 2016
Proposal: Submission of details pursuant to Condition No.4 (landscaping), 6 (cycle store), 7 (energy performance standards) and 8 (SUDS) of planning permission 15/00460/FULPP dated 28 August 2015
Address **Land To Rear Of 39 Meadow Road Farnborough Hampshire**

Application No 15/00993/CONDPP Ward: St Mark's
Applicant: Mr Singh
Decision: **Conditions details approved**
Decision Date: 03 March 2016
Proposal: Submission of details pursuant to conditions 3 (external materials), 4 (surfacing materials), 5 (security gate), 6 (levels), 7 (contaminated land), 9 (secure cycle storage) , 10 (energy performance), 11 (Sustainable Urban Drainage System), 13 (boundaries) and 15 (landscaping) of planning permission 15/00407/FULPP granted 28/08/2015
Address **15 Queens Road Farnborough Hampshire GU14 6DU**

Application No 16/00005/FULPP Ward: Manor Park
Applicant: Mr Paul Riat
Decision: **Permission Granted**
Decision Date: 02 March 2016
Proposal: Retention of shop front with alterations to fascia and stall-riser
Address **185 Victoria Road Aldershot Hampshire GU11 1JU**

Application No 16/00017/FUL Ward: Rowhill
Applicant: Lucasz Zajac
Decision: **Permission Granted**
Decision Date: 29 February 2016
Proposal: Replace 3 windows and 2 doors with white uvpc and replace bay window to front elevation with double glazed sliding wood sash windows
Address **Flat 1 4 Queens Road Aldershot Hampshire GU11 3JD**

Application No 16/00019/CONDPP Ward: Empress
Applicant: Knight Frank Investment Management
Decision: **Conditions details approved**
Decision Date: 11 March 2016
Proposal: Submission of details to comply with conditions 2 (external materials), 3 (surfacing materials), 7 (contaminated land), 10 (landscaping), 13 (lighting strategy), 18 (construction method statement) and 21 (alternative pedestrian route) attached to planning permission 15/00813/FULPP dated 22 December 2015 in respect of the erection of an extension to existing shopping centre to provide two retail units to include external display areas to front, alterations to the external appearance of existing tower feature, creation of rear service yard with access from Hawthorn Road and alterations to existing car park layout and landscaping at Proposed Extension To Princes Mead
Address **Proposed Extension To Princes Mead Westmead Farnborough Hampshire**

Application No 16/00024/FULPP Ward: St Mark's
Applicant: Millstone Homes
Decision: **Permission Granted**
Decision Date: 03 March 2016
Proposal: Erection of carports and free standing refuse store
Address **93 Somerset Road Farnborough Hampshire GU14 6DR**

Application No 16/00026/REV Ward: St John's
Applicant: Mr R Brine
Decision: **Permission Granted**
Decision Date: 22 February 2016
Proposal: Relief of Condition 9 attached to planning permission 05/00270/FUL (for the erection of 141 dwellings) dated 02 December 2005 to allow single storey front and rear extension to existing garage along with the conversion of the garage to a habitable room
Address **21 Maple Avenue Farnborough Hampshire GU14 9UR**

Application No 16/00032/COU Ward: St Mark's
Applicant: Mr Jay Jones
Decision: **Permission Granted**
Decision Date: 11 March 2016
Proposal: Change of use of premises from retail (Use Class A1) to cross-fit training gym (Use Class (D2)
Address **5A Queens Road Farnborough Hampshire GU14 6DJ**

Application No 16/00033/REM Ward: St Mark's
Applicant: Mr Ron Hedges
Decision: **Permission Granted**
Decision Date: 07 March 2016
Proposal: Approval of Reserved Matter: Erection of single storey detached temporary spray booth pursuant to condition 6 of Planning Permission Ref: 09/00313/REVPP dated 10th February 2011
Address **Land Adjacent To D Shed Farnborough Airport Farnborough Road Farnborough Hampshire**

Application No 16/00036/FULPP Ward: St Mark's
Applicant: Mr Grahame Jones
Decision: **Permission Granted**
Decision Date: 10 March 2016
Proposal: Installation of one sub-station (DSSFIL03) in enclosed steel cabinet and relocation of one existing sub-station (FIL03) to new fenced enclosure together with associated ancillary works
Address **Airshow Hall 1 ETPS Road Farnborough Hampshire**

Application No 16/00040/ADVPP Ward: St Mark's
Applicant: Costa Ltd And HEREF Farnborough Ltd
Decision: **Permission Granted**
Decision Date: 09 March 2016
Proposal: Display four internally illuminated fascia signs, one internally illuminated pole sign (5 metres high), one internally illuminated height barrier sign, two free standing internally illuminated 'key seller' signs, one internally illuminated 'triple menu' sign, three 'parking restriction' signs and one 1 'exit' post sign.
Address **Land At Junction With Templer Avenue Meadow Gate Avenue Farnborough Hampshire**

Application No 16/00041/REVPP Ward: St Mark's
Applicant: G B Builders Ltd.
Decision: **Permission Granted**
Decision Date: 04 March 2016
Proposal: Removal of Condition No.15 (sustainability rating certification) imposed by planning permission 14/00919/FULPP dated 13 March 2015
Address **Drakes Cottage 4 Queens Road Farnborough Hampshire GU14 6DH**

Application No 16/00050/FULPP Ward: St Mark's

Applicant: Mr & Mrs M & J Smith

Decision: **Permission Granted**

Decision Date: 25 February 2016

Proposal: Erection of a first floor side extension

Address **112 Park Road Farnborough Hampshire GU14 6LT**

Application No 16/00053/FULPP Ward: Fernhill

Applicant: Mr Chris Barratt

Decision: **Permission Granted**

Decision Date: 22 February 2016

Proposal: Erection of a single storey side and rear extension

Address **Holly Cottage 390 Fernhill Road Blackwater Camberley Hampshire GU17 9HP**

Application No 16/00055/TPOPP Ward: Cove And Southwood

Applicant: Mrs S Clarke

Decision: **Permission Granted**

Decision Date: 16 March 2016

Proposal: One Oak (T27 of TPO 417) crown lift from ground level to no more than 3 metres over car parking area and no more than 4 metres over access road and remove deadwood. One Oak (T26 of TPO 417) clear garage and house by no more than 2 metres, crown lift from ground level to no more than 3 metres remove epicormic growth up to 3 metres and remove deadwood

Address **5 The Oaks Farnborough Hampshire GU14 0QB**

Application No 16/00056/TPO Ward: Rowhill
Applicant: Mr Adam Grist
Decision: **Permission Granted**
Decision Date: 11 March 2016
Proposal: One Oak (part of group G1 of TPO 171) located to rear of 55 Rowhill Avenue, reduce four branches overhanging rear garden of 15 Rhyll Gardens back to the common boundary line as indicated on submitted photograph
Address **55 Rowhill Avenue Aldershot Hampshire GU11 3LP**

Application No 16/00067/NMA Ward: St Mark's
Applicant: G B Builders Ltd.
Decision: **Permission Granted**
Decision Date: 03 March 2016
Proposal: NON-MATERIAL AMENDMENT : Alterations to design of roof approved with planning permission 14/00919/FULPP dated 13 March 2015 to delete flat roof portion
Address **Drakes Cottage 4 Queens Road Farnborough Hampshire GU14 6DH**

Application No 16/00071/FULPP Ward: Empress
Applicant: Mr Russell Ervin
Decision: **Permission Granted**
Decision Date: 23 February 2016
Proposal: Erection of a two storey rear extension, insertion of roof light, replacement porch and garage roof
Address **Verona 27 Highgate Lane Farnborough Hampshire GU14 8AE**

Application No 16/00072/FUL Ward: Cove And Southwood
Applicant: Mr Boas
Decision: **Permission Granted**
Decision Date: 29 February 2016
Proposal: Erection of a two storey side extension
Address **14 Westglade Farnborough Hampshire GU14 0JE**

Application No 16/00075/REXPD Ward: Manor Park
Applicant: Mrs Josie Chillery
Decision: **Prior approval is NOT required**
Decision Date: 22 February 2016
Proposal: Erection of a single storey rear extension measuring 4 metres in length from the original rear wall, 2.4 metres to the eaves and 4 metres overall height
Address **7 Avondale Road Aldershot Hampshire GU11 3HQ**

Application No 16/00079/FUL Ward: North Town
Applicant: Mr And Mrs C Everitt
Decision: **Permission Granted**
Decision Date: 24 February 2016
Proposal: Erection of a conservatory to rear
Address **23 North Lane Aldershot Hampshire GU12 4QF**

Application No 16/00080/COU Ward: Knellwood
Applicant: Mr M. Fowler And Mr A. Draycott
Decision: **Permission Granted**
Decision Date: 25 February 2016
Proposal: Change of use of amenity land to garden land
Address **Land To The Rear Of 15 And 16 Wilton Court Farnborough Hampshire**

Application No 16/00089/FULPP Ward: Knellwood
Applicant: Mr Rafael Ocana
Decision: **Permission Granted**
Decision Date: 07 March 2016
Proposal: Formation of a pitched roof over existing flat roof at first floor level on elevation of property facing Rectory Road and erection of 2 pillars measuring 1.82m in height with coping stones with dwarf wall to provide main access to property□
Address **8 Rectory Road Farnborough Hampshire GU14 7BZ**

Application No 16/00092/FULPP Ward: St Mark's
Applicant: Mr Philip Douglass
Decision: **Permission Granted**
Decision Date: 29 February 2016
Proposal: Erection of a single storey side and rear extension
Address **11 Guildford Road West Farnborough Hampshire GU14 6PS**

Application No 16/00096/REXPD Ward: Manor Park
Applicant: Mr C. Edward
Decision: **Prior approval is NOT required**
Decision Date: 29 February 2016
Proposal: Erection of a single storey rear extension measuring 6 metres in length from the original rear wall, 2.47 metres to the eaves and an overall height of 2.67 metres
Address **16 Northbrook Road Aldershot Hampshire GU11 3HE**

Application No 16/00098/FUL Ward: Rowhill
Applicant: Ms Sian Englefield
Decision: **Permission Granted**
Decision Date: 01 March 2016
Proposal: Erection of part two storey and part single storey rear extension
Address **6 Chetwode Terrace Aldershot Hampshire GU11 3NR**

Application No 16/00099/NMA Ward: Fernhill
Applicant: Mrs C Black
Decision: **Permission Granted**
Decision Date: 26 February 2016
Proposal: Non material amendment to planning permission 13/00717/FUL dated 18 October 2013 to allow change from a 2m high closeboard wooden fence with posts to a 2m high close board effect metal fence with posts along the full length of the common boundary with neighbour no: 283 Pinewood Park
Address **281 Pinewood Park Farnborough Hampshire GU14 9JS**

Application No 16/00101/NMAPP Ward: Empress
Applicant: Fishron Farnborough Limited
Decision: **Permission Granted**
Decision Date: 02 March 2016
Proposal: NON-MATERIAL AMENDMENT: Amendment to design of proposed building approved by Planning Permission 13/00306/FULPP dated 16 October 2013 to delete five projecting balconies from front elevation to be replaced with glazed juliet railings
Address **Development Site At 27 And Adjacent Land Victoria Road Farnborough Hampshire**

Application No 16/00104/COUPP Ward: West Heath
Applicant: Mr Richard Tottle
Decision: **Permission Granted**
Decision Date: 09 March 2016
Proposal: Change of use from amenity land to garden land with a 2 metre high wooden fence
Address **Land To The Side Of 104 Sunnybank Road Farnborough Hampshire**

Application No 16/00107/FUL Ward: Rowhill
Applicant: Mr Robert Harvey
Decision: **Permission Granted**
Decision Date: 02 March 2016
Proposal: Retention of fencing on all boundaries
Address **159 Alexandra Road Aldershot Hampshire GU11 3PP**

Application No 16/00112/FUL Ward: St Mark's
Applicant: Mr Peter Szebeni
Decision: **Permission Granted**
Decision Date: 02 March 2016
Proposal: Replacement windows
Address **32C Southampton Street Farnborough Hampshire GU14 6AX**

Application No 16/00117/COND Ward: Manor Park
Applicant: Cove Construction Ltd
Decision: **Conditions details approved**
Decision Date: 29 February 2016
Proposal: Submission of details pursuant to Condition No.18 (sustainability rating certification) of planning permission 12/00527/FULPP dated 16 November 2012 in respect of Plots 5 and 6 (Nos.1 & 2 Albion Mews)
Address **Albion Works Church Lane East Aldershot Hampshire GU11 3BT**

Application No 16/00121/FUL Ward: Empress
Applicant: Mrs K Stuart
Decision: **Permission Granted**
Decision Date: 10 March 2016
Proposal: Erection of a summer house in rear garden
Address **11 Revelstoke Avenue Farnborough Hampshire GU14 8NG**

Application No 16/00126/HCC Ward: Cove And Southwood
Applicant: Hampshire County Council
Decision: **No Objection**
Decision Date: 04 March 2016
Proposal: CONSULTATION FROM HAMPSHIRE COUNTY COUNCIL: Rooflight replacement
Address **Southwood Infant School Southwood Lane Farnborough Hampshire GU14 0NE**

Application No 16/00127/NMAPP Ward: Empress
Applicant: Provident House Staines Ltd
Decision: **Permission Granted**
Decision Date: 09 March 2016
Proposal: NON-MATERIAL AMENDMENT : Amendment to design of extended building approved by planning permission 14/00651/FULPP dated 22 January 2015 to remove all balconies from first and second floors
Address **61 - 65 Victoria Road Farnborough Hampshire GU14 7PA**

Application No 16/00129/HCC Ward: West Heath
Applicant: WENDY AGOMBAR
Decision: **No Objection**
Decision Date: 04 March 2016
Proposal: HAMPSHIRE COUNTY COUNCIL CONSULTATION: Erection of a canopy
Address **Manor Infants School Fernhill Road Farnborough Hampshire GU14 9DX**

Application No 16/00132/FULPP Ward: Empress
Applicant: Mr And Mrs Dangerfield
Decision: **Permission Granted**
Decision Date: 16 March 2016
Proposal: Erection of a first floor rear extension and replacement of existing single storey flat roof with a pitched roof□
Address **62 Chingford Avenue Farnborough Hampshire GU14 8AD**

Application No 16/00142/FUL Ward: Knellwood
Applicant: Mr P Davidson
Decision: **Permission Granted**
Decision Date: 15 March 2016
Proposal: Retention of a single storey front extension
Address **77 Abbey Way Farnborough Hampshire GU14 7DF**

Application No 16/00143/FUL Ward: Manor Park
Applicant: Mr John Lally
Decision: **Permission Granted**
Decision Date: 16 March 2016
Proposal: Erection of a single storey rear extension following removal of existing conservatory□
Address **32 Highfield Avenue Aldershot Hampshire GU11 3BZ**

Application No 16/00144/HCC Ward: Wellington

Applicant: WENDY AGOMBAR

Decision: **No Objection**

Decision Date: 11 March 2016

Proposal: HAMPSHIRE COUNTY COUNCIL CONSULTATION: Two form entry, two storey primary school with associated parking and external works at the Western School Site, Queens Avenue, Aldershot

Address **Zone I - School End Aldershot Urban Extension Alisons Road Aldershot Hampshire**

Application No 16/00152/NMAPP Ward: St Mark's

Applicant: Mrs C Phillips

Decision: **Permission Granted**

Decision Date: 02 March 2016

Proposal: Non Material Amendment to application 15/00673/FULPP dated 6th October 2015 to allow the retention of French doors and Juliette balcony and an additional window at first floor on the rear elevation

Address **16 South Street Farnborough Hampshire GU14 6LN**

Development Management Committee
30th March 2016

Directorate of Community
and Environment
Planning Report No. PLN1611

Appeals Progress Report

1. New appeals

1.1 There are no new appeals to report.

2. Pending Appeals

2.1 At the meeting of 3rd February 2016 Members were advised of an appeal in respect of the service of an Enforcement Notice alleging the unauthorised change of use of the first floor to a 7 bedroomed house in multiple occupation and 6 self-contained studio flats in the rear part of the building at **The former Beehive Public House, 264 High Street, Aldershot**. The appeal was set to be dealt with by means of the Public Inquiry procedure as the submitted grounds of appeal included Ground (d) (...that, at the date when the notice was issued, no enforcement action could be taken in respect of any breach of planning control which may be constituted by those matters), this being a 'legal' ground of appeal requiring witnesses to be cross-examined under oath. Subsequently notification was received from The Planning Inspectorate that ground (d) had been withdrawn by the appellant and that the appeal will now proceed by way of the written procedure.

2.2 At the same meeting the receipt of an appeal was reported in respect of the service of an Enforcement Notice alleging the change of use from storage and distribution to an 18-bedroom house in multiple occupation comprised of 12 bed-sitting rooms and six rooms with shared facilities at **The Old Warehouse, Star Yard, Victoria Road, Aldershot**. This appeal is also to be dealt with by means of the written procedure.

2.3 Without prejudice to the outcome of these appeals, the appellants are seeking to progress undertakings under S.106 to deal with matters such as SANGs mitigation and financial contributions towards public open space and transportation as appropriate. On the advice of the Solicitor to the Council it is considered that these matters should be dealt with by bilateral S.106 agreements rather than unilateral undertakings. Authority is therefore sought to enter into agreements in respect of both sites.

3. Recommendation

3.1 (a) It is recommended that the report be **NOTED**.

3.2 (b) It is recommended that the Solicitor to the Council is **authorised to enter**

into bilateral agreements under S.106 of the Town and Country Planning Act in respect of the appeal developments at The former Beehive Public House, 264 High Street, and The Old Warehouse, Star Yard, Victoria Road Aldershot.

Keith Holland
Head of Planning